

C SOURCE

CUSTOM MERCHANDISING SOLUTIONS



High Capacity Clothing Hang Bars (HB-2) *see page 9*

CALL TODAY (360) 424-1129 x 104
csource.wirefabco.com

PREMIERE PROVIDER OF QUALITY CUSTOM AND STOCK WAREHOUSE FIXTURE SOLUTIONS

MAJORS AREA UPGRADE



TV DISPLAY UPRIGHTS

PN: DS-1(48") & DS-1HD (68")

This innovative frame design provides unrestricted space for storing inventory beneath the display platform. Ideal for widescreen TV's in the majors' area. The DS-1HD version has a thicker frame and 68" wide horizontal for a larger TV display platform.

Features:

- 2 pc construction
- 4 bolt design
- 0.25" thick lateral gusset support

Specifications:

- 61" high
- 48" wide (DS-1)
- 68" wide (DS-1HD)
- 24" x 0.25 thick base
- Rack green powder coat finish

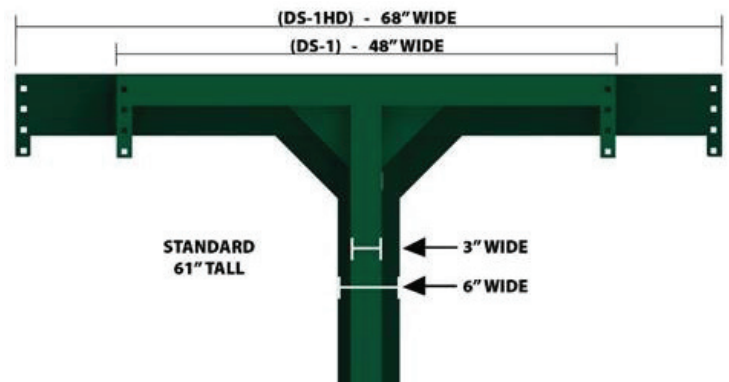

Note: Each 9' bay requires (2) TV Display Uprights and (2) TV Display Table Top sections. All items are sold separately, 9' orange steel beams not available.



TV DISPLAY UPRIGHTS & TABLETOPS



TV DISPLAY TABLETOP WITH CABLE MANAGEMENT

PN: CM-1/HD* (media shelf)

CM-2/HD* (wire shelf)

*Compatible with the 68" wide DS-1HD

Bring cable management under control. Each compact, TV Display Tabletop section comes with your choice of cable management shelf and works exclusively with our TV Display Uprights. The media shelf is designed to mount control modules while the wire shelf is used for managing cords and cable bundles.



Bottom view with media shelf



Bottom view with wire shelf

Features:

- Tool free, modular, drop-in design
- Heavy-duty HDPE and steel material
- Non-conductive surface
- Choice of cable management shelf

Specifications:

- 52" length
- 44.5" wide (CM-1 & CM-2)
- 64.5" wide (CM-1HD & CM-2HD)

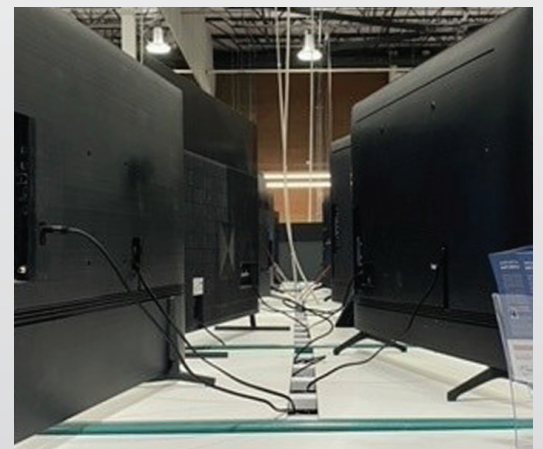
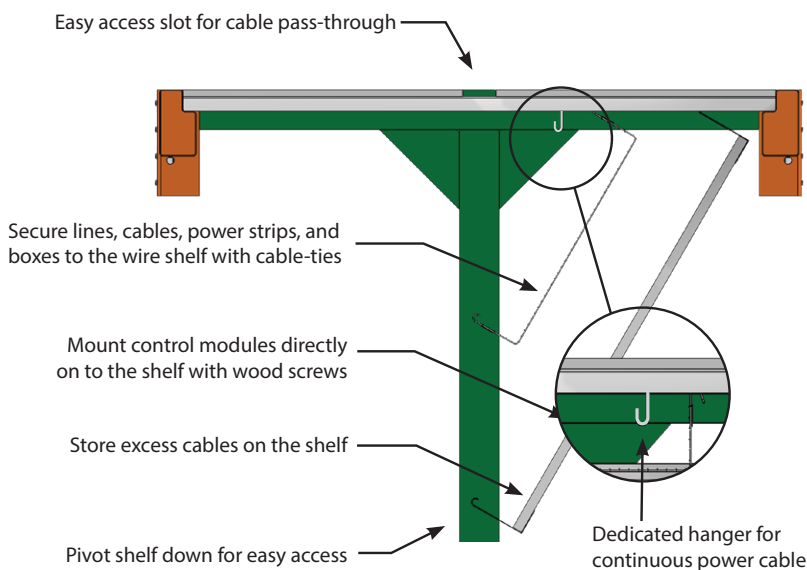

MAJORS AREA UPGRADE

ADJUSTABLE TV ACCESSORY ARM

Attaches to the TV Display Upright, the Adjustable TV Accessory Arm provides multiple display options and space for storing boxed inventory in front.

PN: DA-2/HD

Adjustable TV Accessory Arm

DA-2 is Compatible with the 48" Wide DS-1

DA-2HD is Compatible with the 68" wide DS-1HD

PN: DA-2HD
(for DS-1HD)

PN: DA-2
(for DS-1)



TV DISPLAY ACCESSORIES

TV Mounting Bracket, TV Angle Sign Bar and T-Bar Shelf are designed to attach to the Adjustable Accessory Arm or 2" square tube T-Bars. Items sold separately.

PN: DA-3HD

TV Mounting Bracket HD
50"-80"TV's up to 150lbs

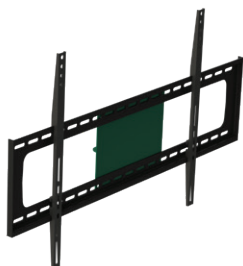

PN: DA-3

TV Mounting Bracket
32"-55"TV's up to 70lbs



PN: DA-4

TV Angle Sign Bar

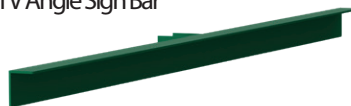

PN: TBS-1

T-Bar Shelf

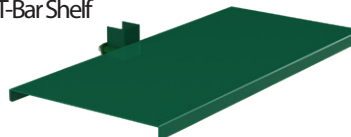

ADJUSTABLE MOUNTING BAR

PN: ATB-5

Create freestanding displays for TV's and other electronics in the majors area. With the Adjustable Mounting Bar you can add a TV Mounting Bracket, Angle Sign Bar, and T-Bar Shelf to showcase a wide variety of merchandise.

Features:

- 1- adjustable vertical assembly
- 1- 24" base
- Standard 3/8" hardware included

Specifications:

- Adjusts 55" to 82" high
- 2" sq tube
- 24" base
- Powder coated steel

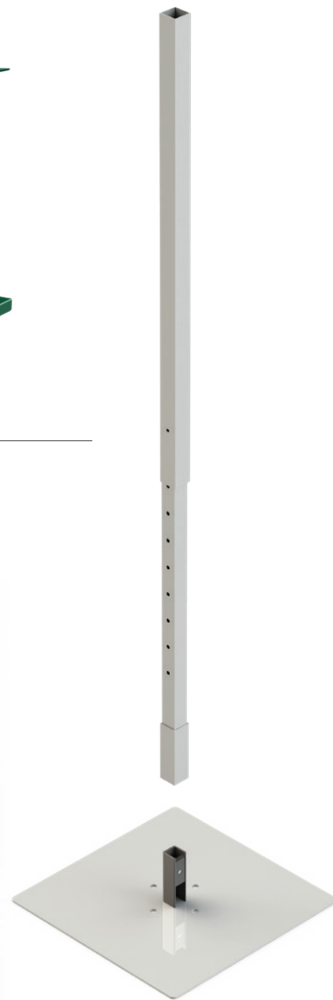

DISPLAY ACCESSORIES



TV RETENTION T-BAR

PN: RB-1

Designed to support merchandise stored beneath the platform. Quick release vertical for removing boxed TV's.

Features:

- 1- 31" vertical bar
- 1- 10" base

Specifications:

- 31" high
- 12" wide
- 10" base
- Powder coated steel

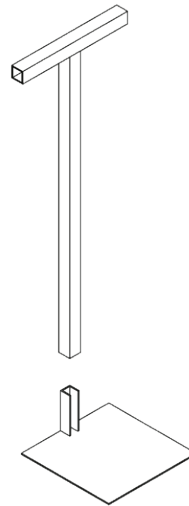

ADJUSTABLE RETENTION BAR

PN: RB-4

Designed to support merchandise stored beneath the platform and adjusts to accommodate a wider range of sizes. Quick release vertical for removing boxed TV's.

Features:

- 1- adjustable vertical assembly
- 1- 10" base

Specifications:

- Adjusts 31" to 49" high
- 12" wide
- 10" base
- Powder coated steel

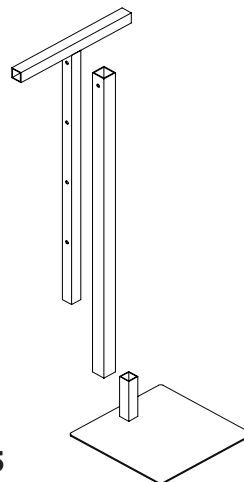

METAL TABLETOPS

Upgrade from melamine to our Metal Tabletops for superior durability and compatibility with your existing steel. Perfect for showcasing clothing, books, baked goods, and more. Our tabletops offer longevity and customizable options to suit your specific needs.

Without Stiffeners

Additional support is recommended for maximum load bearing capability

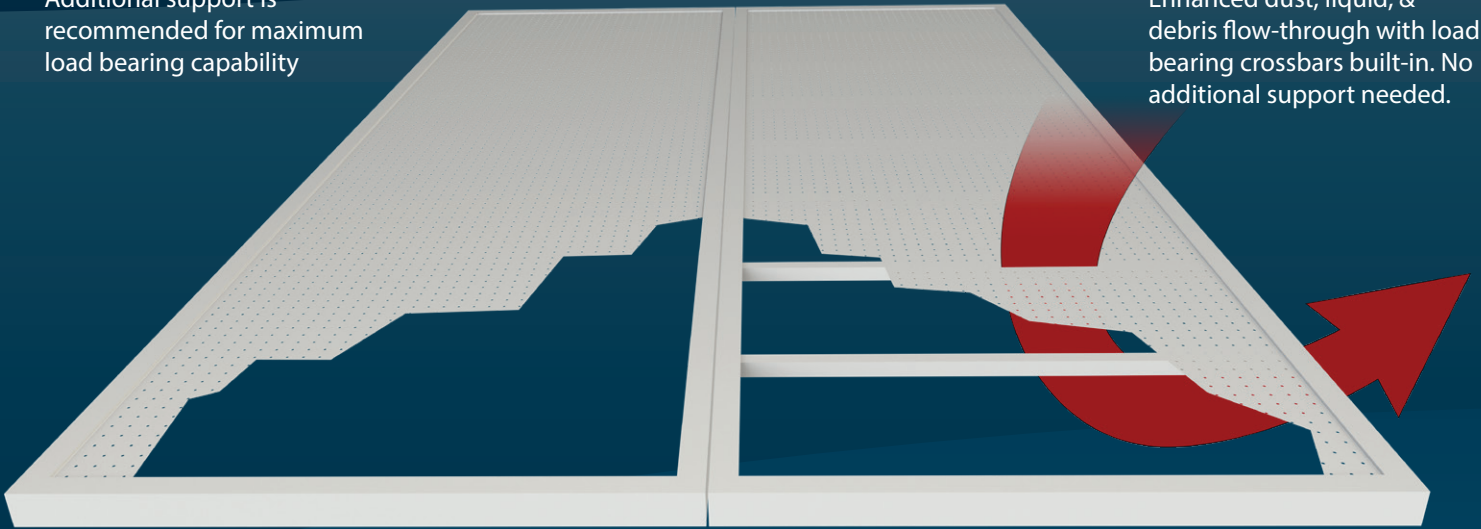

With Stiffeners

Enhanced dust, liquid, & debris flow-through with load bearing crossbars built-in. No additional support needed.

Depending on the configuration of your uprights, you'll choose between wide-fit or narrow-fit tabletops. Wide-fit extends beyond the green steel to accommodate the **spacer bracket that connects both of the uprights.**

Narrow Fit

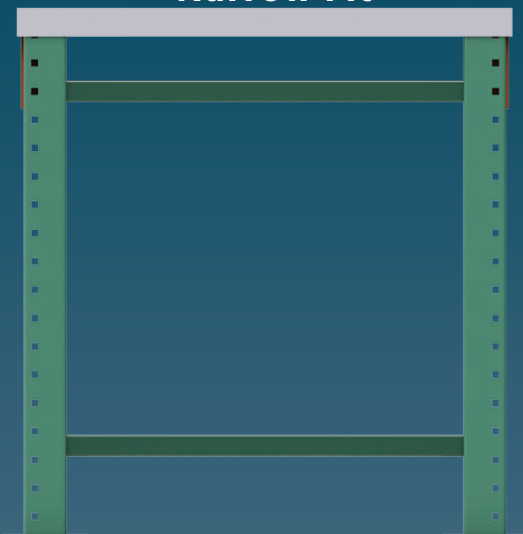

Wide Fit

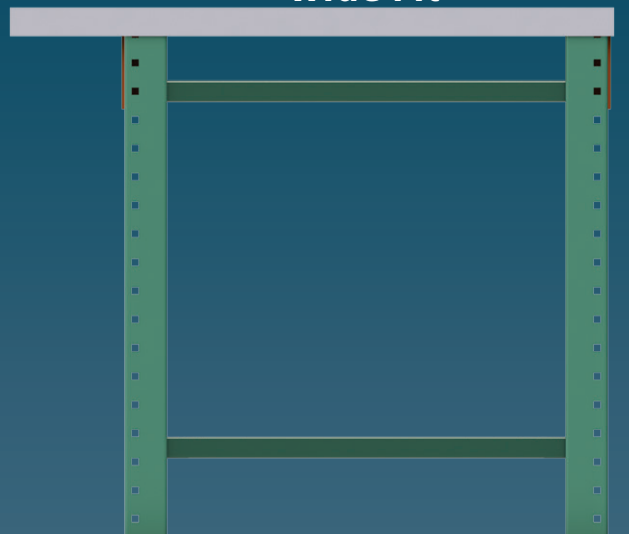

EXPERIENCE THE BENEFITS OF METAL TABLETOPS

Features:

All metal construction
Perforated steel surface
Available with or without stiffeners

Specifications:

Available for 9' long tables
2" high frame
Powder coat finish

Narrow Fit

PN: TT-1 9' Narrow Fit, With Stiffeners

PN: TT-6 9' Narrow Fit, No Stiffeners

Wide Fit

PN: TT-2 9' Wide Fit, With Stiffeners

PN: TT-5 9' Wide Fit, No Stiffeners

Call for more details about custom sizes and colors.



Note: Shown with 2 wide fit table tops installed using a spacer bracket.

TABLE TOP EDGE GUARDS

Extend the life of your melamine with our Tabletop Edge Guards. Crafted from heavy-gauge metal, these guards provide robust protection, ensuring clean, smooth edges and corners for your tables

Features:

- All metal construction
- Quick and easy to install
- Powder coated finish

Specifications:

- 2" high frame
- Custom fit to table size
- Fine thread machine bolts

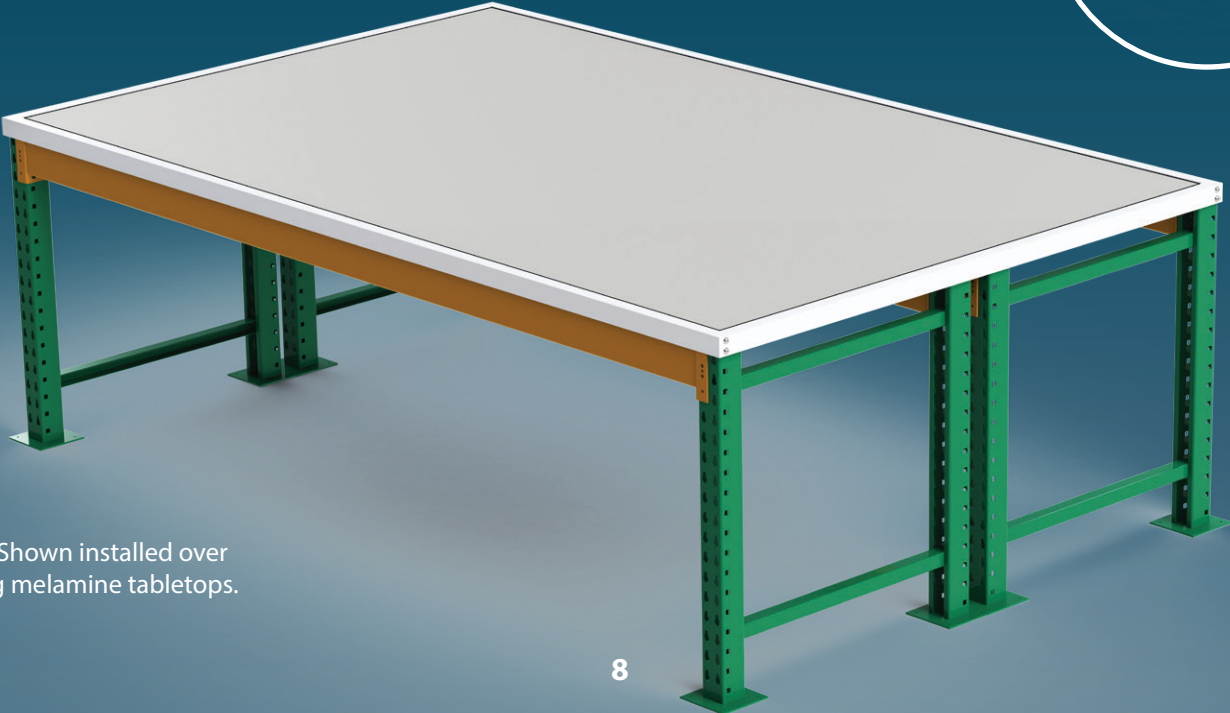
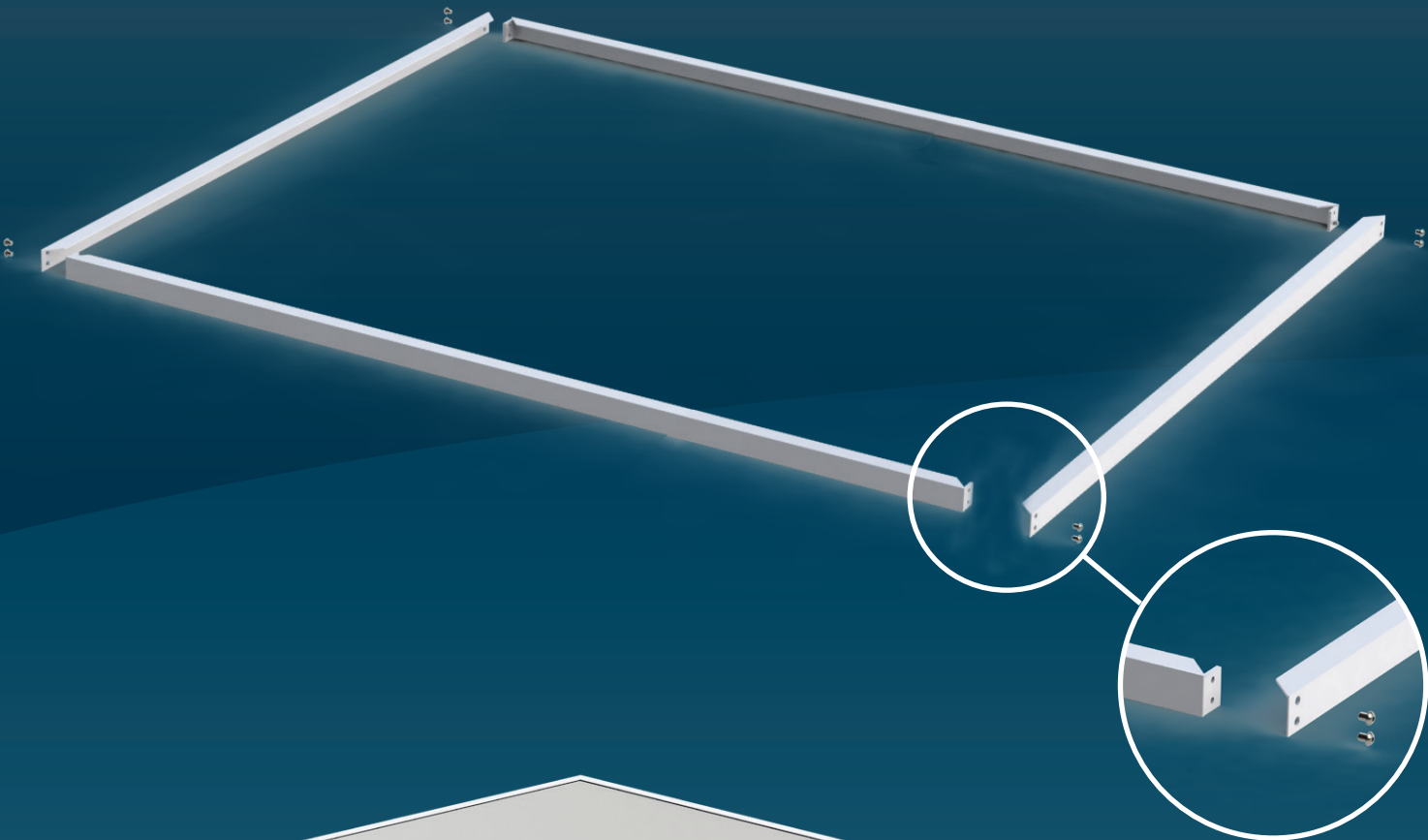

Note: Shown installed over existing melamine tabletops.

HIGH CAPACITY CLOTHING HANG BAR

PN: HB-2

The ultimate display for your hang stock is our new High-Capacity Clothing Hang Bar. Weight restrictions apply.

Features:

1.50" round tube, 2" gussets, adjustable length, mini T-Bar sign pole, fits standard 34" wide steel uprights

Specifications:

56.5" wide
Expandable to fit 6' to 9' beams
Powder coated finish

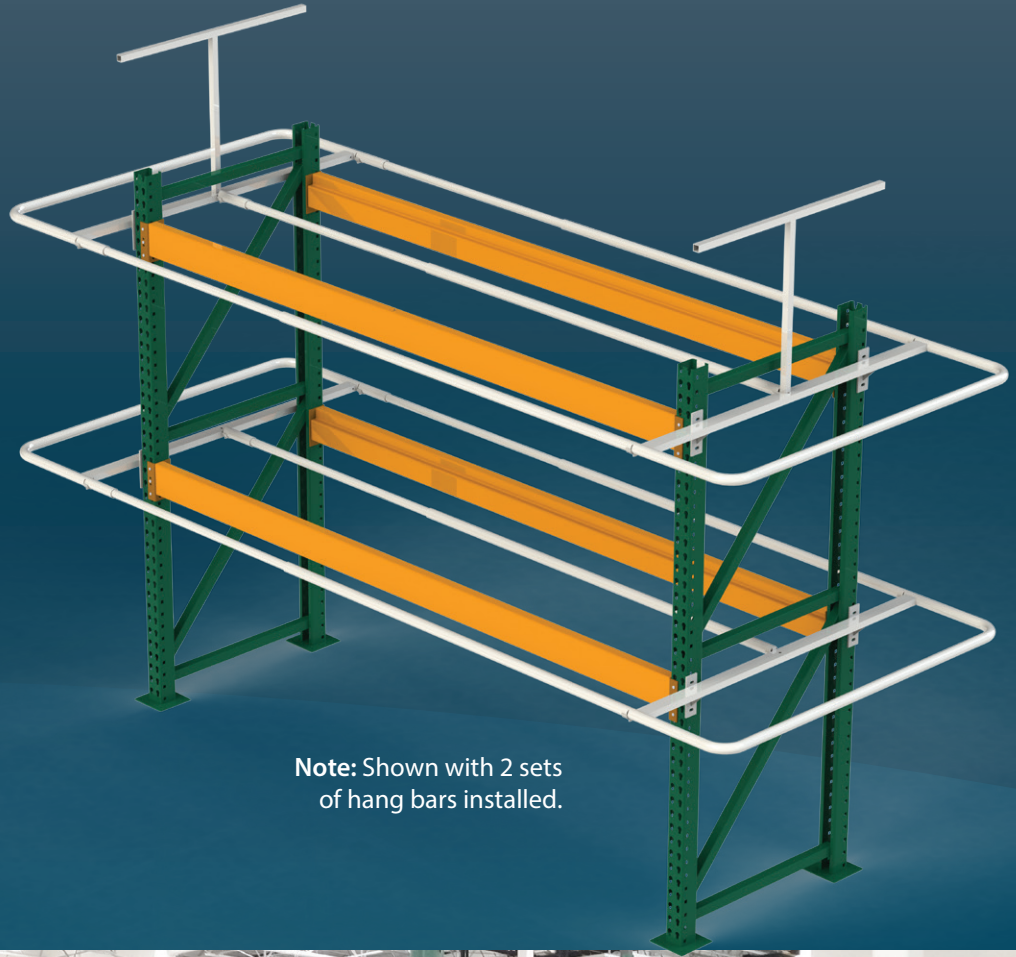

Note: Shown with 2 sets of hang bars installed.



HIGH CAPACITY CLOTHING HANG BAR EXTENSION

Easily converts 9' sections to 18' continuous hanging sections.

Features:

4 bolt design, 2" gussets

Specifications:

56.5" wide

3/8" mounting hardware included

Powder coated finish

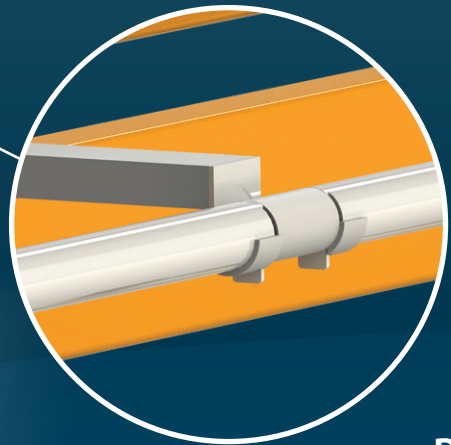
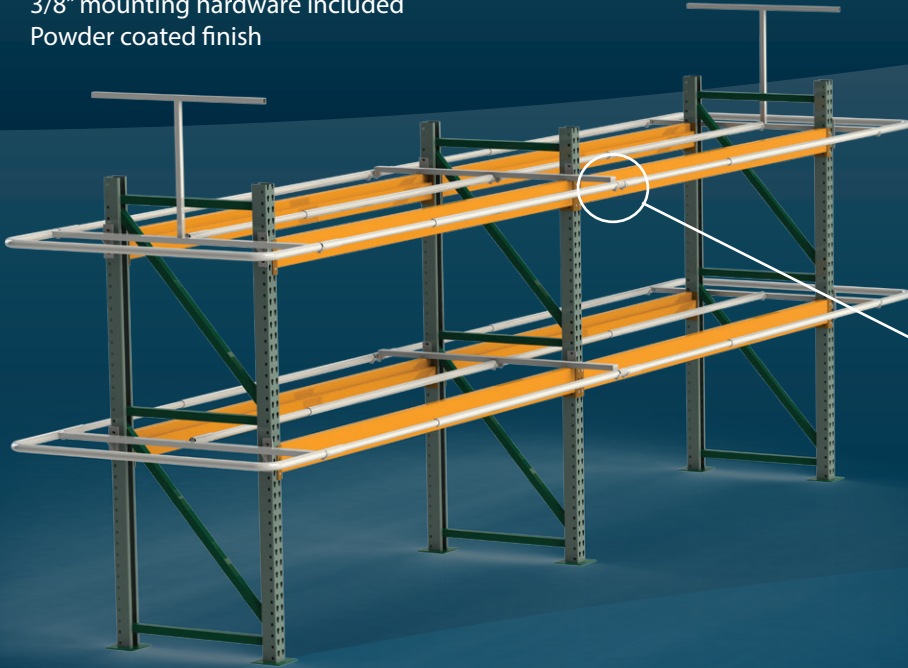
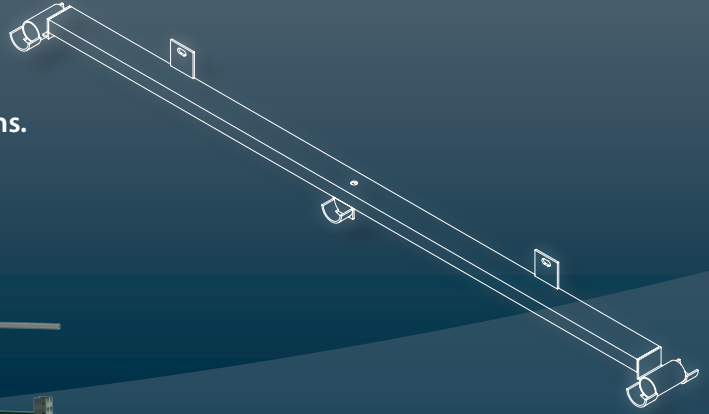

PN: HB-3

HIGH CAPACITY CLOTHING HANG BAR VERTICAL DISPLAY ARM

A set of two vertical extensions that work in combination with our High Capacity Hang Bar (HB-2).

PN: HB-6

Backstock Bar
(included with High Capacity Hang Bar)

Angle Sign Bar - DA-4
(Sold Separately)

High Capacity Hang Bar - HB-2
(Sold Separately)

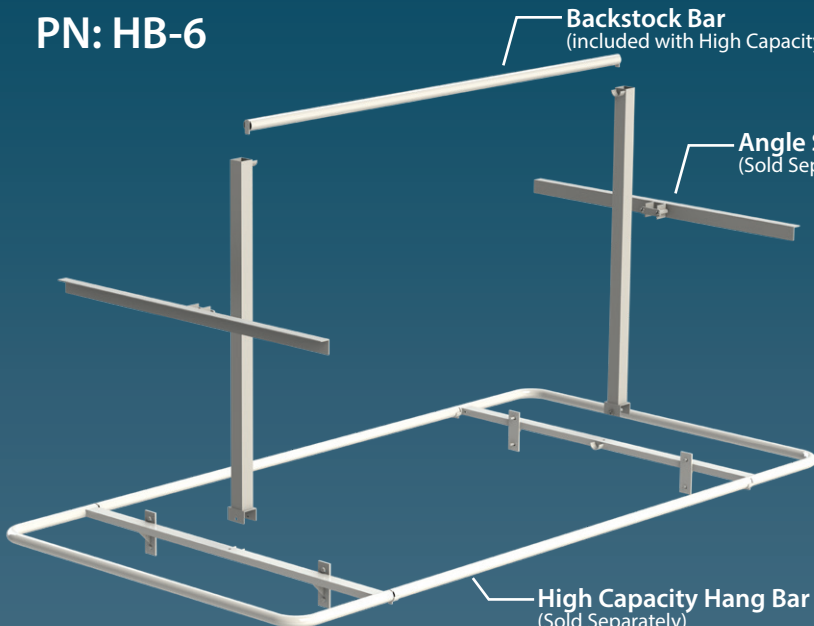
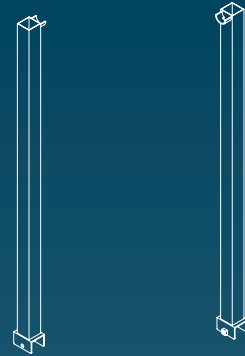



HIGH CAPACITY CLOTHING HANG BAR SUPPORT BRACKET

Designed for use on a standard 9' beam, this bracket supports High Capacity Clothing Hang Bars (HB-2) when displaying heavier garments.

PN: HB-4 for Ridg-U-Rak Steel

PN: HB-5 for Hannibal Steel

HIGH CAPACITY CLOTHING HANG BAR STORAGE FIXTURE

Designed to be fastened on a standard sized pallet. The PALette Hang Bar Storage Solution is capable of storing eight sets of High Capacity Clothing Hang Bars (HB-2) with accessories. It can be stored securely in your pallet racking and moved around on a pallet jack or forklift.

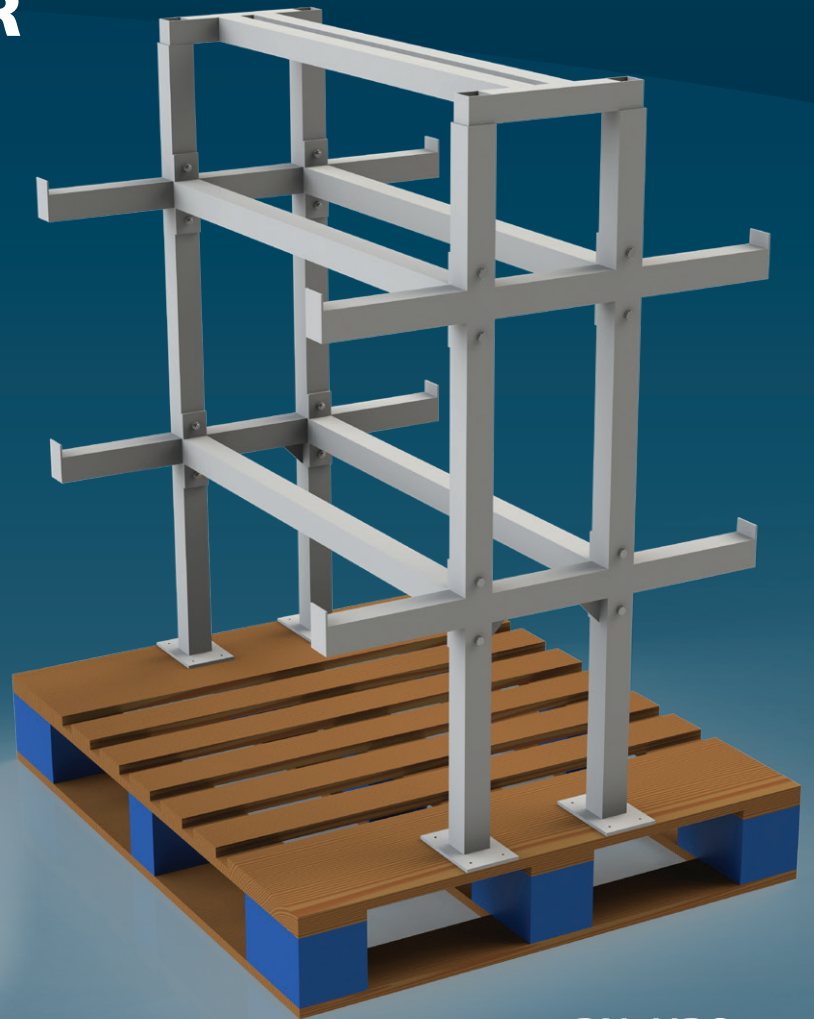
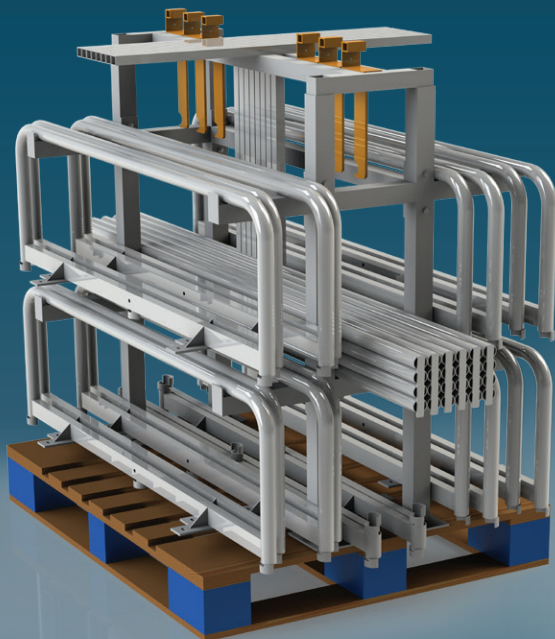

Note: Shown with 8 sets of hang bars and accessories, sold separately.

PN: HBS-1

TBar SYSTEM

Modular Merchandising Solutions

Wirefab/CSource's 44+ years of fixture design and engineering know how, has resulted in a line of effective warehouse merchandising fixtures with premium quality and value.

The true merit of a modular system lies in the durability, and adaptability of its combined components. This is achieved with the use of the SturdyLock technology, a solid yet simple tensioning system that can withstand the challenges of the ever changing warehouse floor. All CSource modular T-Bars have integrated SturdyLock so there is no hardware to contend with, making for quick assembly, easy storage, and endless options to meet any merchandising challenges.

STURDY LOCK!
MODULAR WITH

UNLOCKED POSITION

3/8" HEX WRENCH
THE ONLY TOOL REQUIRED FOR FULL ASSEMBLY

LOCKED POSITION



NO MORE FULLY WELDED T-BARS

DID YOU KNOW?
We can ship

20 T-BARS
ON ONE PALLET
3-PC MODULAR

and...

18 T-BARS
ON ONE PALLET
2-PC MODULAR

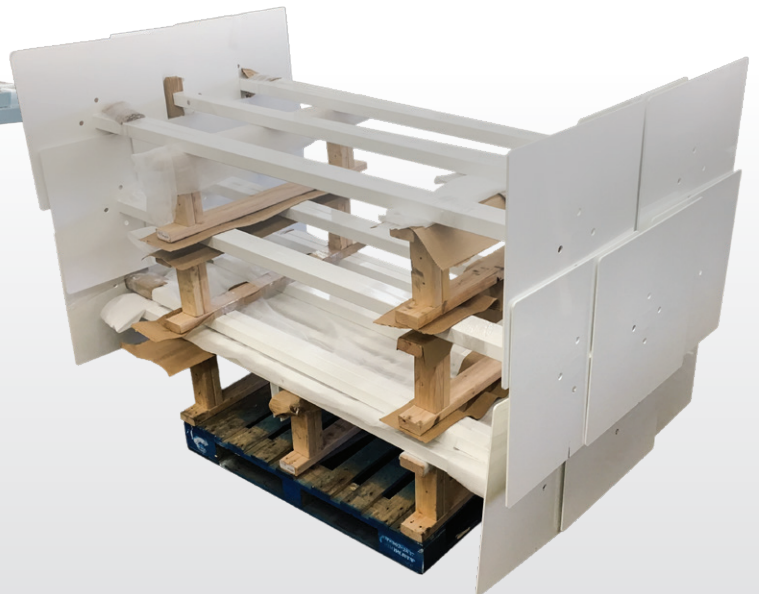
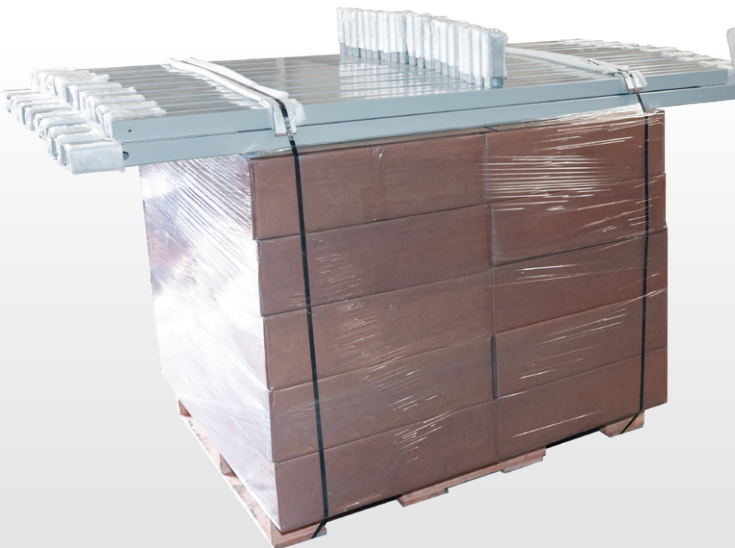

MODULAR T-BAR MERCHANDISING SYSTEM

Developed by Merchandising Managers -- engineered and built by Wirefab / CSource

LARGE T BARS

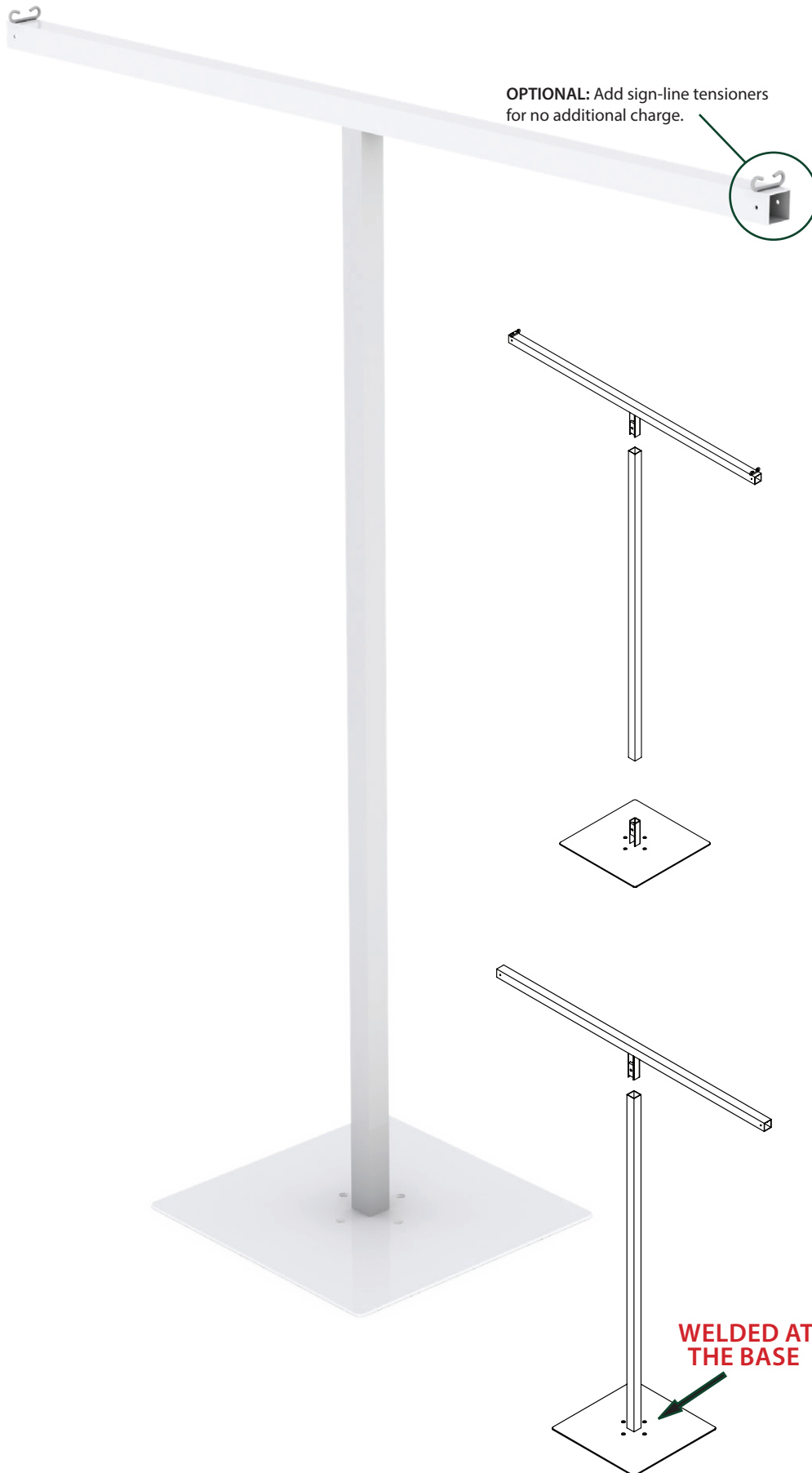

OPTIONAL: Add sign-line tensioners for no additional charge.



3-PIECE

PN: TB-1

The standard T-Bar with the additional benefit of modularity. Allows for quick and easy take-down and set-up to reduce back injuries. Components efficiently store in the back room. Best if combined with the 3pc Storage PALette (see page 16).

Features:

- 1- large horizontal bar
- 1- large vertical bar
- 1- 12" or 24" base

Specifications:

2" sq tube, 84" high, 76" wide, 24" base, Powder coated steel (custom sizes available)

2-PIECE

PN: TB-3

The standard T-Bar with the additional benefit of modularity. Allows for quick and easy take-down and set-up to reduce back injuries. Components efficiently store in the back room. Best if combined with the 2pc Storage PALette (see page 17).

Features:

- 1- large horizontal bar
- 1- large vertical bar welded to 12" or 24" base

Specifications:

2" sq tube, 84" high, 76" wide, 24" base, Powder coated steel (custom sizes available)



SMALL TBARS

3-PIECE

PN: TB-2

Designed for use with table or pallet stacks. The Small T-Bar set seamlessly interchanges with the Large T-Bar components and all T-Bar shelving systems.

Features:

- 1- small horizontal bar
- 1- small vertical bar
- 1- 12" or 24" base

Standard Specs:

2" sq tube, 42" high, 60" wide, 12" or 24" base,
Powder coated steel (custom sizes available)



2-PIECE

PN: TB-4

Designed for use with table or pallet stacks. The 2pc Small T-Bar set interfaces with other modular T-Bar components and T-Bar shelving systems.

Features:

- 1- small horizontal bar
- 1- small vertical bar welded to 12" or 24" base

Standard Specs:

2" sq tube, 42" high, 60" wide, 12" or 24" base,
Powder coated steel (custom sizes available)

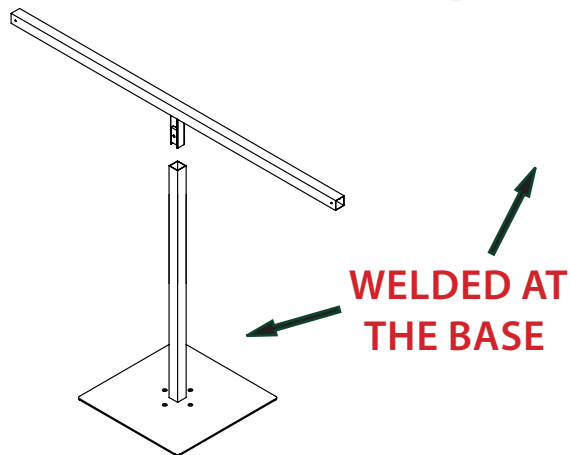

SMALL 1" | 2-PIECE

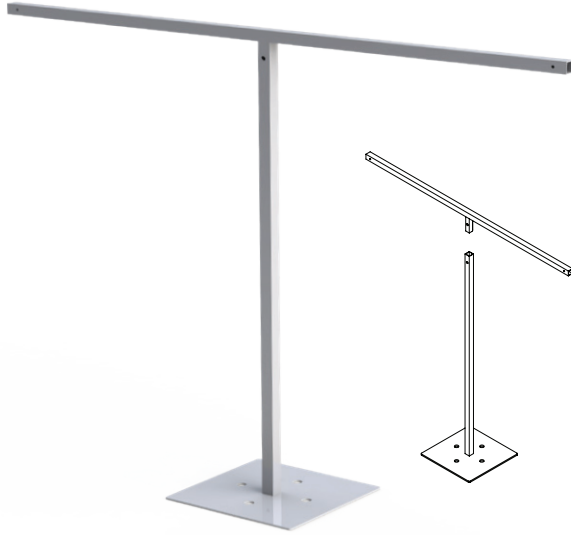

PN: TB-7

Designed for use with table or pallet stacks in centers, our new 1" T-Bar is a light-weight, cost-saving alternative to the 2" sq. tube T-Bar.

Features:

- 1- small horizontal bar
- 1- small vertical bar welded to a 6" or 12" base

Standard Specs:

1" sq tube, 42" high, 48" wide, 6" or 12" base, Powder coated steel (custom sizes available)

PRODUCE T-BAR

PN: TB-10 (3-PIECE) TB-11 (2-PIECE)



Smaller than our Large T-Bar, for use in the produce area. These T-Bar components interface with other modular T-Bar components and T-Bar shelving systems.

Features:

- 1- large horizontal bar
- 1- large vertical bar
- 1- 12" or 24" base

Specifications:

2" sq tube, 72" high, 60" wide, 24" base, Powder coated steel (custom sizes available)

PALETTE (3PC) T-BAR STORAGE SOLUTION

PN: TBP-1

Designed with the same footprint of a standard sized pallet. The PALette 3pc T-Bar Storage Solution is capable of storing up to twelve modular 3pc T-Bars along with six T-Bar shelves. It can be stored securely in your pallet racking, and moved around on a pallet jack or forklift.

Features:

- 1- pallet base
- 1- tube storage module
- 1- base storage module
- 1- shelf storage rack

Specifications:

40" x 48", 54" tall, Powder coated steel
(90" tall loaded with standard T-Bars)

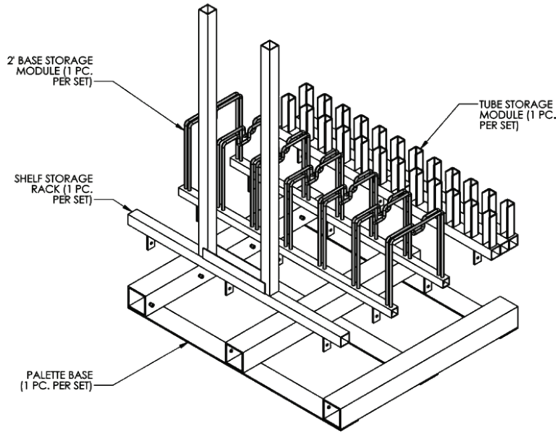

**SAFELY MOVE AND
STORE T-BARS AROUND
YOUR WAREHOUSE**



Note: Shown loaded with (12) Large, 3pc T-Bars and Accessories. T-Bars and Accessories are sold separately.

PALETTE (2PC) T-BAR STORAGE SOLUTION

PN: TBP-2

Designed to be fastened on a standard sized pallet. The PAlette 2pc T-Bar Storage Solution is capable of storing modular 2pc T-Bars. Easily and securely store T-Bars in your pallet racking, or move them around with a pallet jack or forklift.

Features:

1- fully welded palette base

Specifications:

50" x 48", 7.5" tall, Powder coated steel



Note: 24" base version shown above loaded with (6) Large 2pc T-Bars. T-Bars are sold separately.

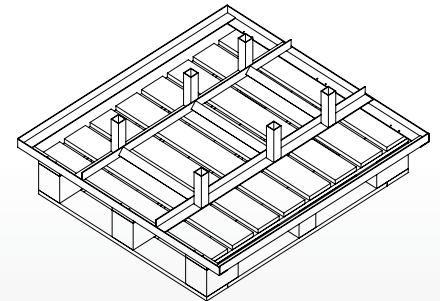

**24" BASE VERSION
HOLDS (6) 2PC T-BARS**

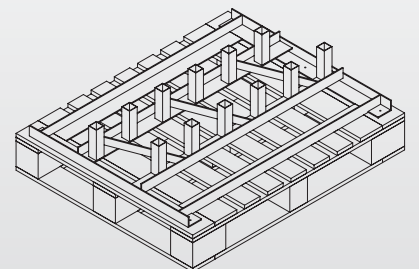

**12" BASE VERSION
HOLDS (12) 2PC T-BARS**

ADJUSTABLE T-BAR

PN: ATB-1

This versatile T-Bar adjusts in height from 56" to 84" in three inch increments, opening the door to a whole new range of merchandising possibilities, like challenging seasonal displays. These T-Bar components interface with other modular T-Bar components and T-Bar shelving systems.

Features:

- 1-adj. vertical bar assembly
- 1-horizontal bar
- 1-24" base
- Standard 3/8" hardware included

Specifications:

- Adjusts 56" to 84" high, 60" wide, 24" base,
- Powder coated steel

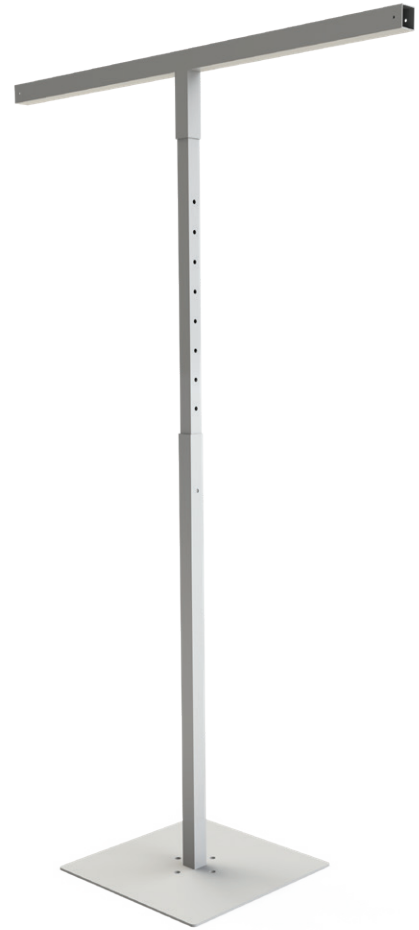
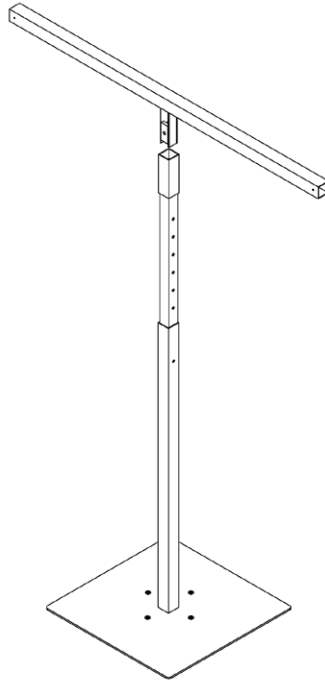

ADJUSTABLE SIGN LINE POLE

PN: ATB-2

A great solution for sign posting fence line pick-stock. The adjustable cable pole is capable of running sign line at varying heights between 78" and 108".

Features:

- 1- adjustable sign-line assembly
- 1- 24" base
- Standard 3/8" hardware included

Specifications:

- Adjusts 78" to 108" high, 24" base,
- Powder coated steel

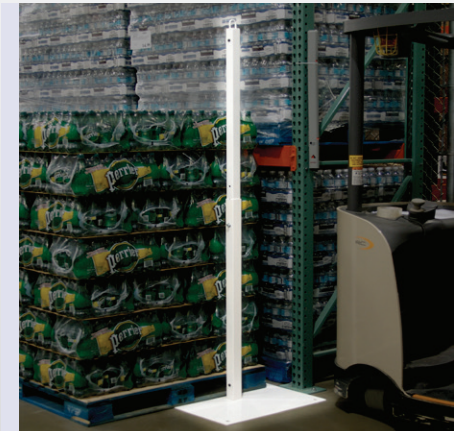
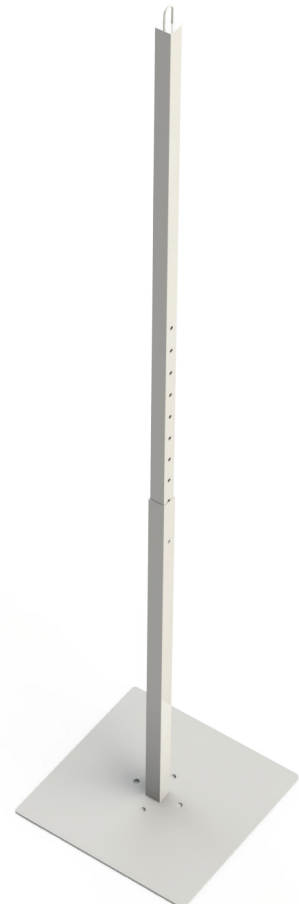
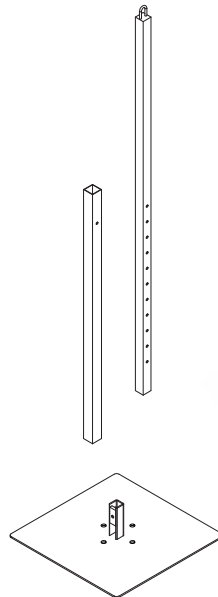

T-BAR DISPLAY ARM

PN: TBA-1

Designed to attach to any standard 2" T-Bar.
Conveniently displays hanging merchandise.

Also available in: 1" clamp design. (PN:TBA-2)

Features:

Easy installation, no sharp edges, powder coat finish

Specifications:

36" high, 5" wide hanger,
3/8" mounting hardware included
Powder coated steel

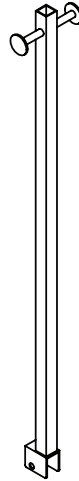

T-BAR EXTENDED SIGN BAR

PN: TB-9

Designed to extend the sign bar space. Attaches to 2" square T-Bar.

Features:

1- horizontal sign bar extension

Specifications:

32" wide x 32" deep
3/8" mounting hardware included
Powder coated steel

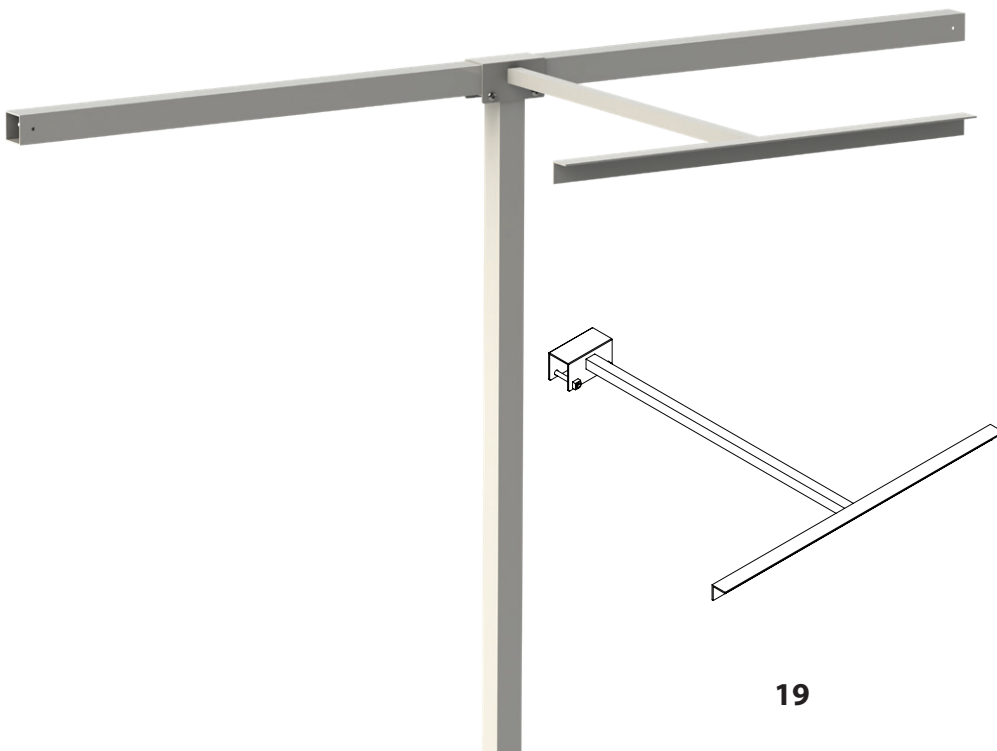

LARGE FREESTANDING ADJUSTABLE SHELF

PN: ATB-4

Originally designed with two shelves, the new large adjustable freestanding shelf will accommodate larger TV's and a variety of merchandise such as bicycles and seasonal items. Multiple shelves can be placed in series to extend the display platform.

Features:

- 1- adjustable vertical bar assembly
 - 1- large shelf with zip-tie mounting holes
 - 1- 24" base
- Standard 3/8" hardware included

Specifications:

Adjusts 44" to 62" high, 48" wide x 32" deep shelf, 24" base, Powder coated steel



T-BAR TOP SHELF

PN: TBS-2

Developed to 'float' display models. Designed for mounting on a standard 2" square tube.

Also available in larger size (PN:TBS-3)

Features:

- Zip-tie mounting holes on shelf
- 3/8" mounting hardware included

Specifications:

TBS-2 - 48" wide x 32" deep

TBS-3 - 60" wide x 36" deep

Powder coated steel

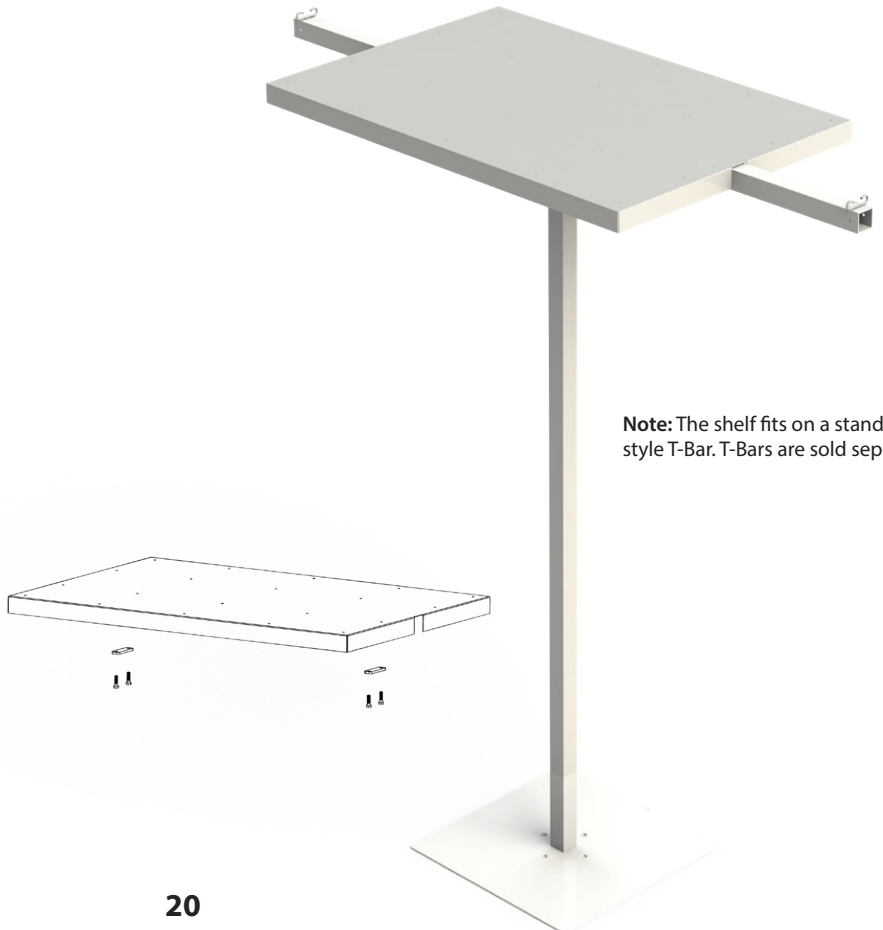

Note: The shelf fits on a standard 2" style T-Bar. T-Bars are sold separately.

FREESTANDING ADJUSTABLE SHELF

PN: ATB-3

This adjustable freestanding shelf has been used in many creative ways to merchandise a wide variety of items. One example is to place the shelf within a 4-square to display electronic items.

Features:

- 1- adjustable vertical bar assembly
- 1- large shelf with zip-tie mounting holes
- 1- 24" base
- Standard 3/8" hardware included

Specifications:

Adjusts 44" to 62" high, 24" base, 48" wide x 14.5" deep, Powder coated steel



T-BAR SHELF

PN: TBS-1

Developed to 'float' display models. Designed for mounting on a standard 2" square tube.

Features:

- Zip-tie mounting holes on shelf
- 3/8" mounting hardware included

Specifications:

32" wide, 14.5" deep, Powder coated steel

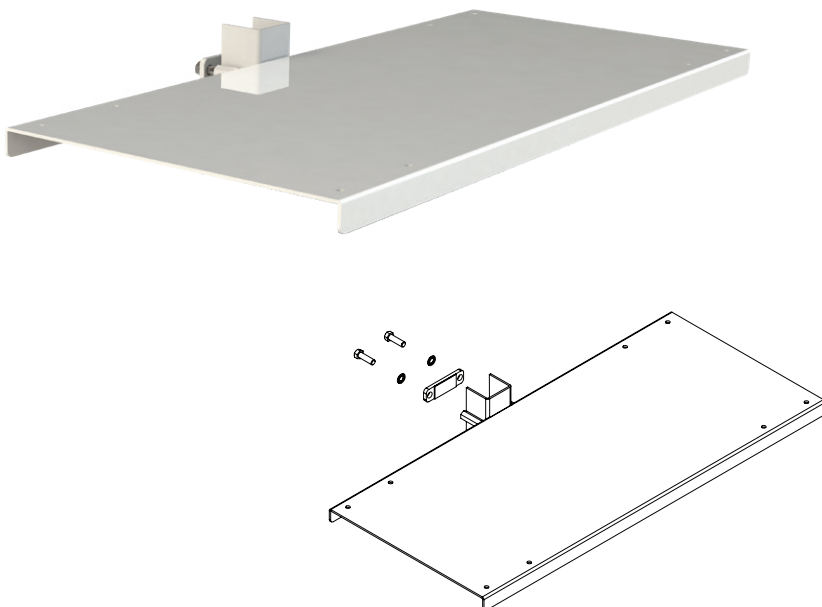

PRODUCT DISPLAY TABLE & ADD ON SHELF

PN: PD-1

The newly redesigned Product Display Table features reinforced shelves for supporting heavyweight merchandise. The knockdown design provides cost efficient shipping and convenient back room storage.

Features:

Heavy duty frame, reinforced shelves, fits 40"x 48" pallet

Specifications:

48" high, 39.75" wide, 47.75" long, equal shelf spacing: 22", Black powder coated steel

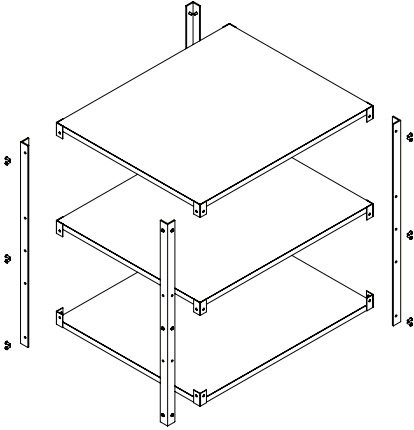

PN: PD-2

The optional Add-On Shelf offers versatility to the Product Display Table and allows for a wide variety of merchandise to be displayed with less open display space.

Features:

Heavy duty frame, reinforced shelf

Specifications:

Equal shelf spacing becomes: 14"
Black powder coated steel

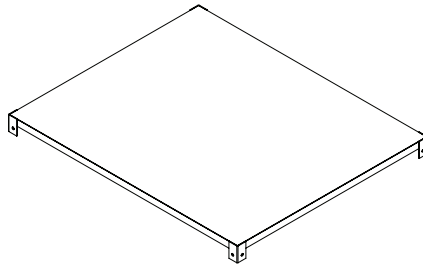

Note: Configuration in back shows the Product Display Table with Add On Shelf included, items are sold separately.

PLANT T-BAR

PN: TB-6

Convenient for plant displays. Modularity allows for quick and easy take-down and setup. Components efficiently store in the back room.

Features:

- 1- horizontal bar with fixed vertical bar
- 1- 10" x 10" base

Specifications:

- 36" high, 24" wide, 10" x 10" base,
- Powder coated steel



PLANT SIGN BAR

PN: TB-8

Designed for the garden center to be used as a single plant sign holder. Lightweight design for easy and convenient use and storage.

Features:

- 1- vertical bar with 5"x7" fixed sign plate
- 1- 10" x 10" base

Specifications:

- 36" high, 10" x 10" base, Powder coated steel

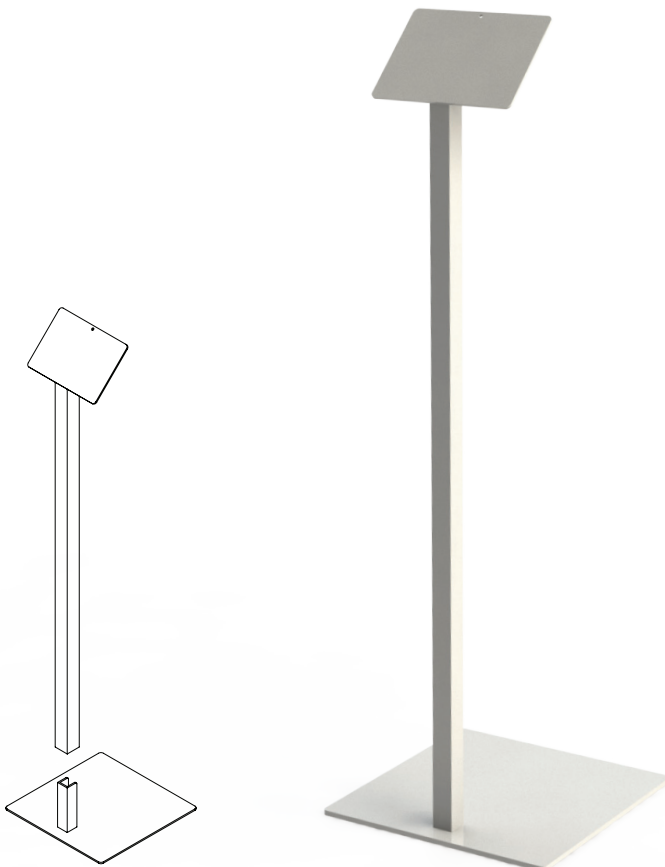

HEIGHT ADJUSTABLE FOLDING TABLE

PN: FT-1

Designed to provide a balanced combination of functionality, ergonomics and durability, the folding table is your best defense in the relentless battle of keeping folded goods tidy and soft-lines moving.

Features:

All metal construction, fold-out top surface, adjustable height, 3.5" bumpers

Specifications:

18" wide, 38.5" length, 35"-42" high, fold-out top surface adds 18", 4" swivel/non-marking casters, Black powder coat finish



Note: The blue folding board is sold separately.



FLIP-FOLD FOLDING BOARD

PN: FB-1

FlipFOLD can fold any size shirt (small-XXXL) to a uniform size 9"x12" in five seconds, for a consistent uniform fold every time.

Features:

Fits in folding table holder, no sharp edges



TABLE PRODUCT SUPPORT

PN: PS-1

Designed to stabilize products displayed on tables. This durable support is ideal for organizing blister packs, folded garments, or other slippery merchandise. Available in multiple sizes.

Features:

- Clear, durable PETG material
- Radial corners with no sharp edges
- High friction feet to prevent sliding

Specifications:

- PS-1** - 12" high, 12" wide, 7.5" deep
- PS-3** - 12" high, 36" wide, 7.5" deep (Wide)
- PS-4** - 12" high, 46" wide, 7.5" deep (Extra-wide)
- PS-5** - 12" high, 12" wide, 7.5" deep (Corner)



ABOVE: Corner option (PS-5)
LEFT: Standard size (PS-1)

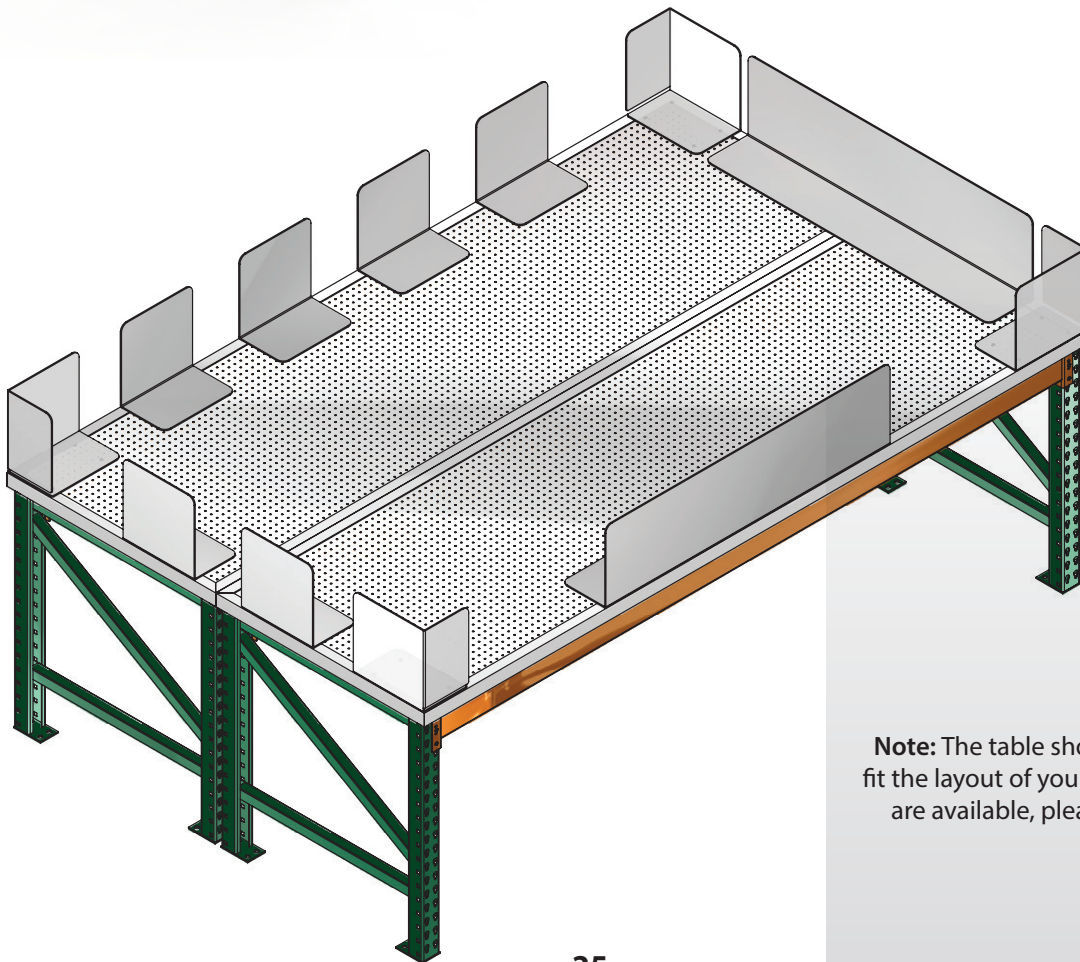

Note: The table shows various sizes to fit the layout of your table. Custom sizes are available, please call for details.

CARDBOARD BOX BIN

PN: BB-1

Convenient storage for empty cardboard boxes. Easy to maneuver with large 5" swivel casters.

Features:

1" square tube, 5" polylock swivel casters, knock-down design for storage

Specifications:

41" deep x 73" wide x 43" high
White powder coated steel

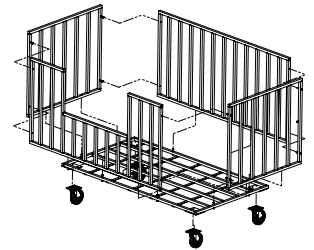

SLANTED PILLOW BIN

PN: PB-2

Designed to manage and merchandise various soft-line items. CSource Pillow Bins are easy to assemble and disassemble for convenient storage when not in use.

Features:

1" square tube, knock-down design for storage

Specifications:

48" long x 40" wide x 48" high
White powder coated steel

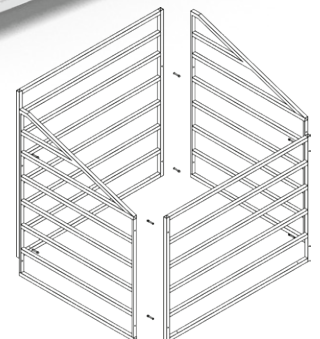

CHAIR STOP

PN: CS-1

Designed to secure office chairs to display platforms. The Chair Stops are easy to install using wood screws.

Sold in sets of 2.

Specifications:

3.5" diameter, 5" high, 1.75" deep, Powder coat satin black finish

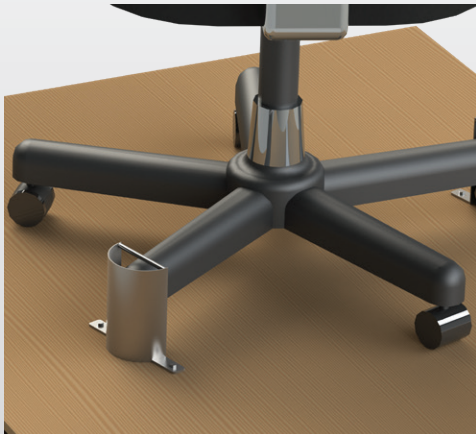

TENT DISPLAY T-BAR

PN: TD-1

Designed to display fully assembled small tents and light weight inflatable products. The vertical pole is 108" tall. The product support arm is 48" wide and adjusts in length from 7' to 9'. The 24" wide base plate must be securely bolted to the floor.

Features:

- 1- 24" base
- 1- 108" vertical pole
- 1- Products support arm assembly

Specifications:

Product support arm adjusts 7' - 9'; Powder coated steel

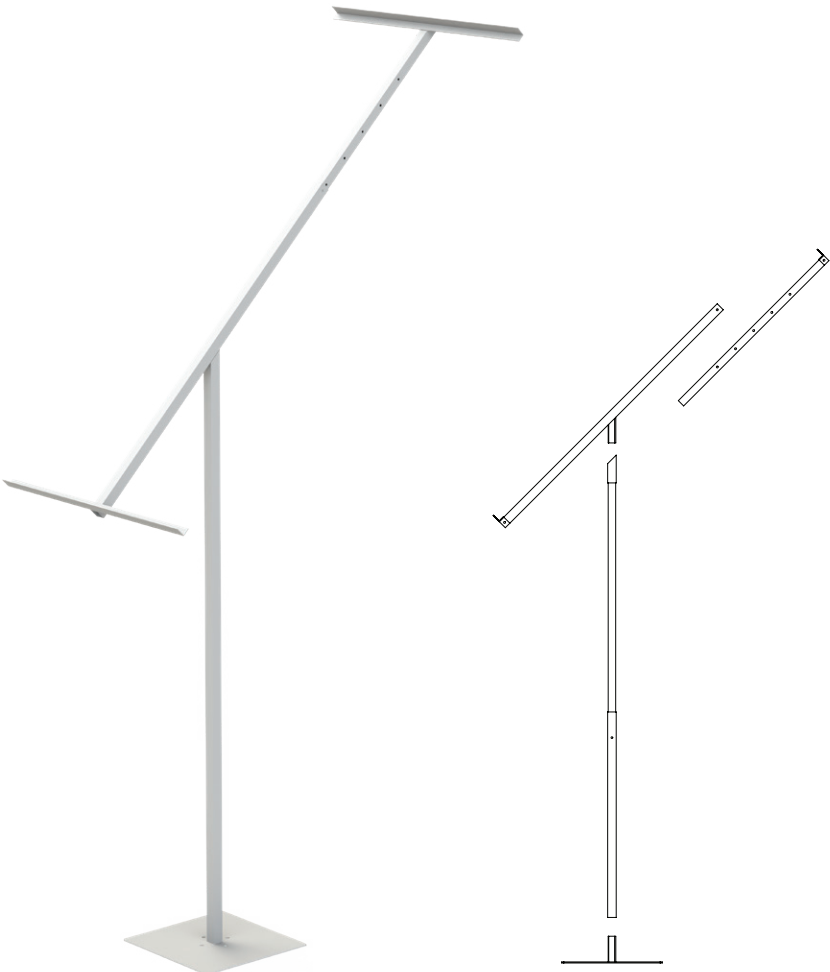

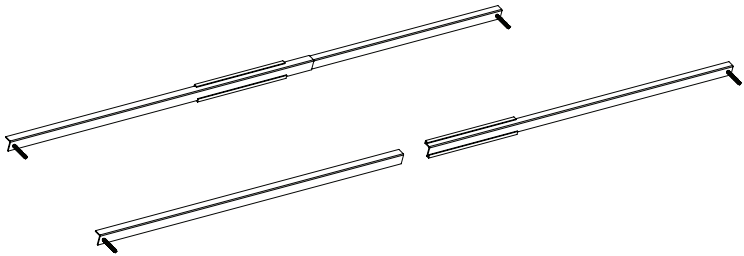

ADJUSTABLE ANGLE SIGN BAR

PN: AAH-1

Designed to expand and mount to all steel end caps. Two bolts attach the sign bar easily to the steel upright. Very economical to ship.

Features:

Adjustable and easy to install
1/8" thick steel

Specifications:

1" x 1 1/2" formed angle
adjusts 53" to 88"
Green powder coat finish

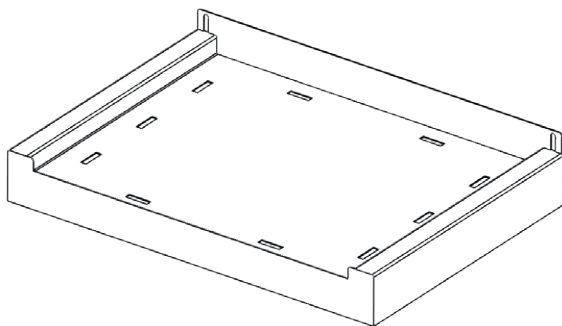

END-CAP SHELF

PN: RW-1

A refined solution for end-cap shelving, this attractive, low-profile shelf enhances the presentation of display items and elevates the appearance of the entire department. Weight restrictions apply.

Features:

Easy mounting
secure strap slots
3/8" mounting hardware included

Specifications:

34" wide, 24" deep, 3" high
Durable powder coat finish



Note: Cantilever arms not included.

RACKWORKS is the go-to collection for smart and simple fixtures designed to optimize merchandise organization. Display various merchandise in your hardlines using the green steel uprights in your warehouse.

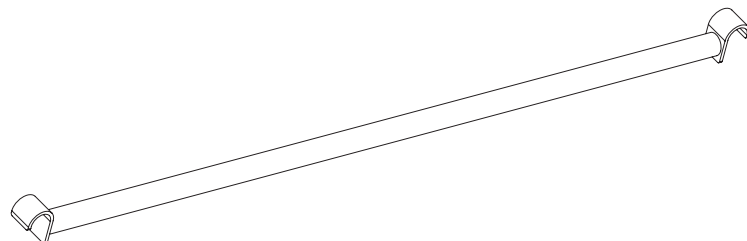

FACE-IN BARS

PN: RW-2

Face-In Bars work in unison with Face-Out Bars, allowing hang stock to be merchandised in an easy access, face-in position. This is ideal for all clothing and sportswear such as jackets, wet-suits and life preservers.

Features:

- 1.25" round tube
- Easy-set design
- Face-Out Bar compatible

Specifications:

- 47.5" wide
- Black powder coat finish

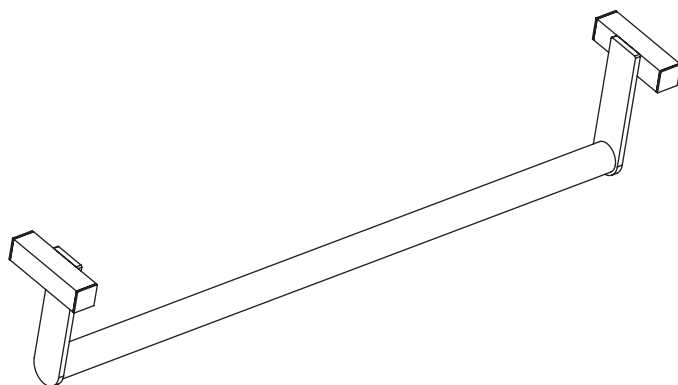

FACE-OUT BARS

PN: RW-3

Solve the challenge of merchandising standard and seasonal hang-stock. Individual RackWorks Face-Out Bars easily arrange to support and display all types of hanging items in an outwardly facing position.

Features:

- 1.25" round tube,
- Easy-set span design,
- Face-In Bar compatible

Specifications:

- 30.5" wide, 6" drop
- Black powder coat finish

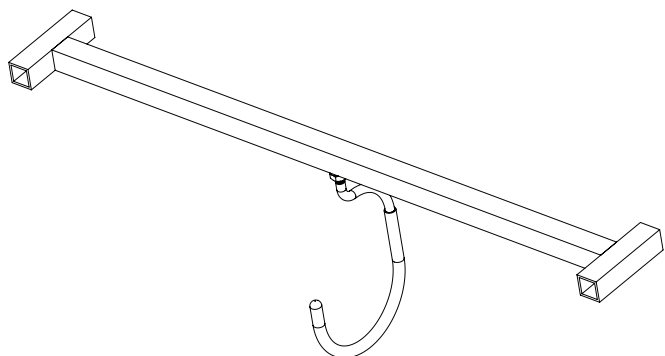

BIKE BARS

PN: RW-4

Streamline bicycle merchandising with easy-set adjustable Bike Bars. The custom wide-mouth hook makes mounting and removal easier by accommodating nearly all wheel and tire sizes.

Features:
easy-set design
wide mouth hook
protective rubber sleeve

Specifications:
30.5" wide, 9" drop
black powder coat finish

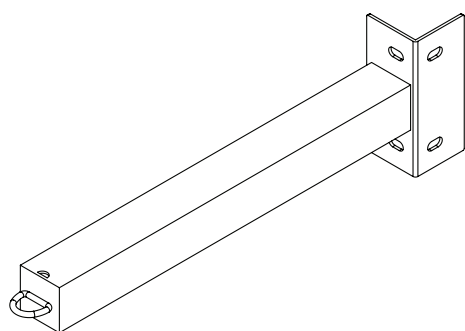

PALLET RACK SIGN BAR

PN: RW-5

The simple yet ingenious solution for warehouses seeking to display signage beyond vertical uprights or along their fences. Designed to tackle common signage challenges, this versatile fixture effortlessly enhances visibility in the trickiest spaces.

Features:
2" square tube

Specifications:
18" long
powder coated finish
3/8" mounting plate

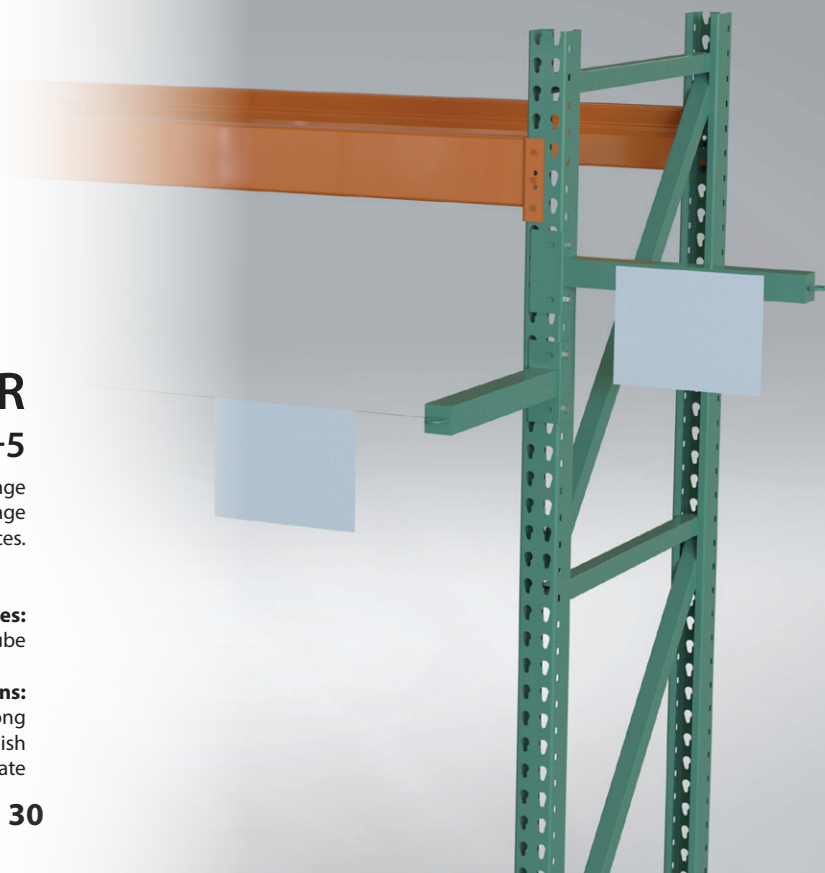

RACK WORKS PALLET RACK MERCHANDISING SOLUTIONS

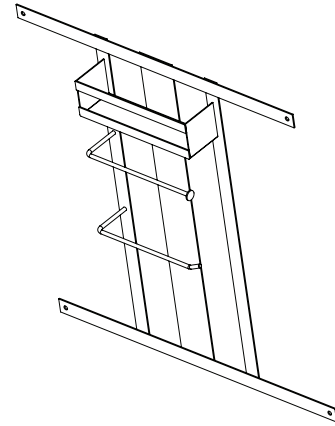
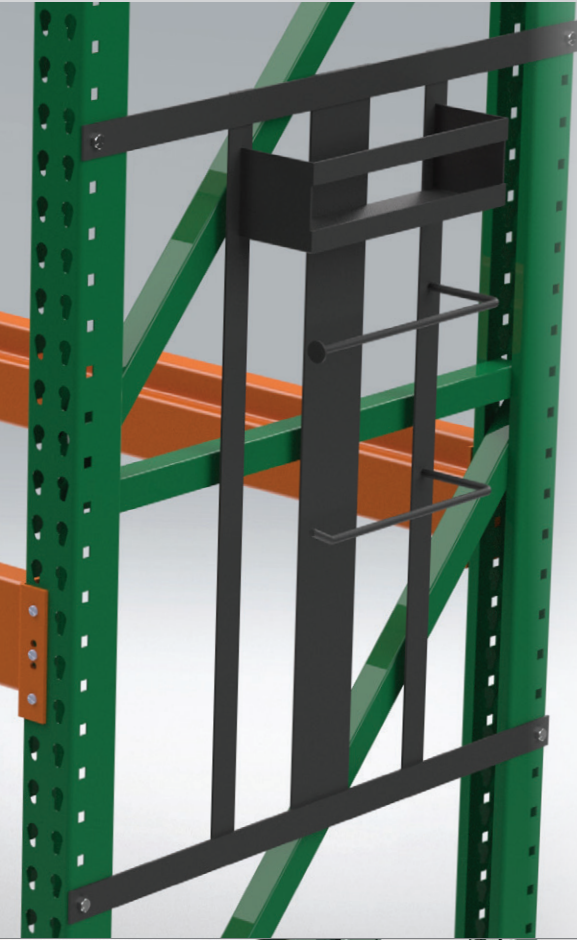

HAZMAT STATION

PN: HS-1

The ultimate solution for warehouse spill response. Engineered to securely hold essential supplies like gloves, paper towels, and garbage bags, this station ensures swift and efficient cleanup in hazardous situations, enhancing safety and readiness in your warehouse.

Features:

rubber glove box holder,
paper towel arm, and plastic bag arm

Specifications:

34" wide, 36" high
powder coated finish
3/8" mounting holes

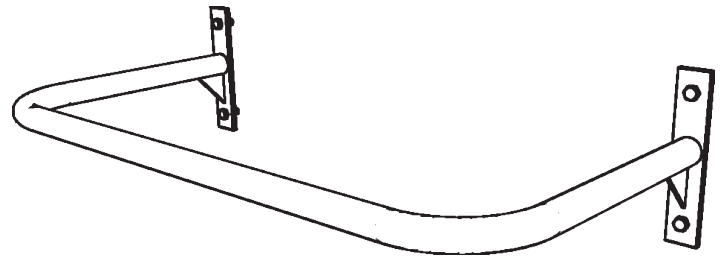

CLOTHING HANG BAR

PN: HB-1

The best way to expand your hang stock capacity is with our Clothing Hang Bar. (100lbs Hang weight capacity)

Features:

1.25" round tube

Specifications:

34" wide, 16" deep
powder coated finish
3/8" mounting hardware included



Custom Merchandising Solutions

CALL TODAY (360) 424-1129 x104
csource.wirefabco.com



Height Adjustable Folding Table (FT-1) see page 24



We design and manufacture custom retail displays and products, delivering superior quality and maximum return on your investment. Whether you have existing designs or need our team's expertise, we offer creative, practical, and tailored solutions. Our in-house prototyping and efficient offshore production ensure competitive pricing and industry-leading quality. From design to delivery, we're your ideal partner.

**CUSTOM FIXTURES
MADE TO ORDER
YOU DESIGN IT, WE'LL MAKE IT!**

Partner with CSource by Wirefab to bring your best merchandising ideas to life. Share your concepts and specifications (dimensions and descriptions are key!) and we'll create custom fixtures quickly and easily.



1012 W. Division Street
Mount Vernon, WA 98273

csource.wirefabco.com

Call or Email us for a price list and order form, or visit our website!
Questions, or need assistance with ordering? CALL US (360) 424-1129 - ext 104.