

C SOURCE

CUSTOM MERCHANDISING SOLUTIONS



TV Display Uprights *see pg. 2*

TV Display Table Top With Cable Management *see pg. 3*

CALL TODAY 888.861.9303 or 360.424.1129
csource.wirefabco.com

PREMIERE PROVIDER OF QUALITY CUSTOM AND STOCK WAREHOUSE FIXTURE SOLUTIONS

MAJORS AREA UPGRADE



TV DISPLAY UPRIGHT

PN: DS-1

This innovative frame design provides unrestricted space for storing inventory beneath the display platform. Ideal for wide screen TV's in the majors' area.

Features:
2 pc construction
4 bolt design
0.25" thick lateral gusset support

Specifications:
61" high
48" wide
24" x 0.25 thick base
Rack green powder coat finish

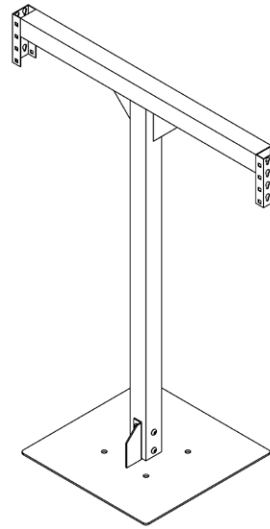

HD TV DISPLAY UPRIGHT

PN: DS-1HD

Similar to the DS-1, this upright has a thicker frame and wider cross arm allowing for larger TV's to be displayed on the platform.

Features:
2 pc construction
4 bolt design
0.25" thick lateral gusset support

Specifications:
61" high
68" wide
24" x 0.375 thick base
Rack green powder coat finish

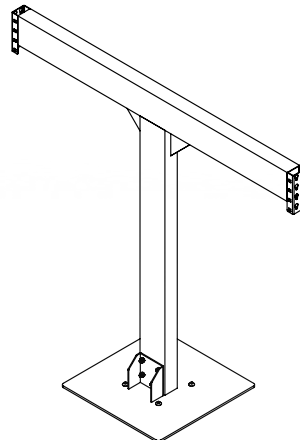

DISPLAY UPRIGHT ACCESSORIES



Note: Shown as complete system using two TV Display Tabletop Sections, TV Display Uprights & 9' orange steel beams. All items are sold separately.

TV DISPLAY TABLE TOP WITH CABLE MANAGEMENT

Compatible with the 48" wide DS-1

PN: CM-1 (with Media shelf)

PN: CM-2 (with Wire shelf)

Compatible with the 68" wide DS-1HD

PN: CM-1HD (with Media shelf)

PN: CM-2HD (with Wire shelf)

Bring cable management under control. This compact, cable management system, works exclusively with the CSource TV Display Uprights (DS-1 & DS-1HD).

Each 9' bay requires (2) TV Display Table Top sections and your choice of cable management. The media shelf is designed to mount control modules and the wire shelf is designed for managing power and cable bundles.

Features:

Tool free, modular, drop-in design

Heavy duty HDPE, non-conductive tabletop

Basket and media shelf options for cable management

Specifications:

Non-conductive Plascoat finish

52" Length section

44.5" Wide (CM-1 & CM-2)

64.5" Wide (CM-1HD & CM-2HD)

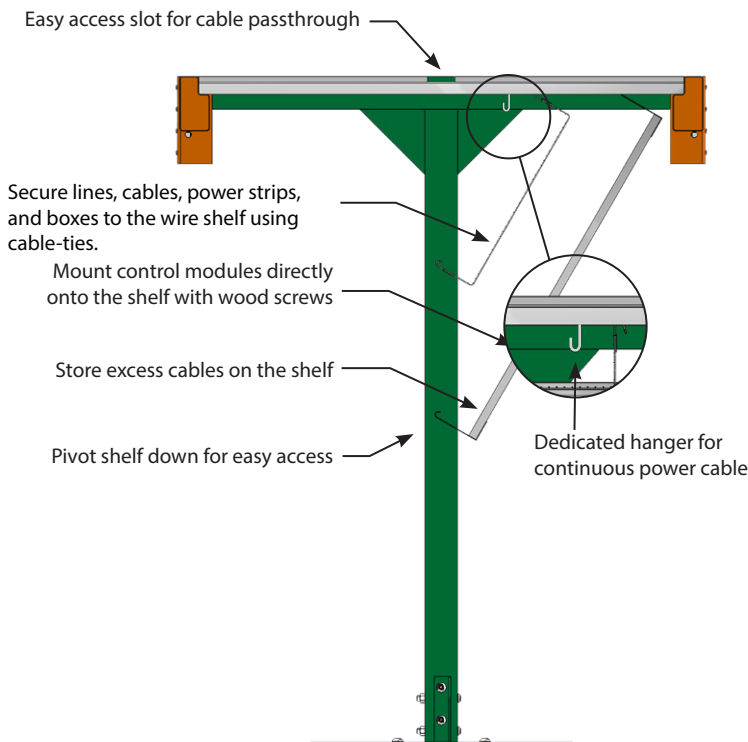

Bottom view featuring the Media Shelf



Bottom view featuring the Wire Shelf

DISPLAY UPRIGHT ACCESSORIES

ADJUSTABLE TV ACCESSORY ARM

Attaching to the TV Display Upright, the Adjustable TV Accessory Arm provides multiple display options and space for storing boxed inventory below.

PN: DA-2
Adjustable TV Accessory Arm
For use with 48" Wide DS-1

PN: DA-2HD
Adjustable TV Accessory Arm HD
For use with 68" Wide DS-1HD

TV DISPLAY ACCESSORIES

TV Mounting Bracket, TV Angle Sign Bar and T-Bar Shelf are designed to attach to the Adjustable Accessory Arm or 2" square tube T-Bars. Items sold separately.

PN: DA-3HD
TV Mounting Bracket HD
50"-80" TV's up to 150lbs

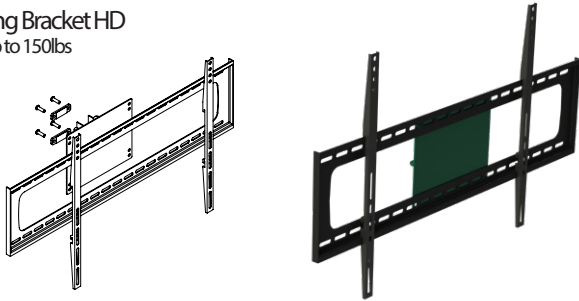

PN: DA-3
TV Mounting Bracket
32"-55" TV's up to 70lbs

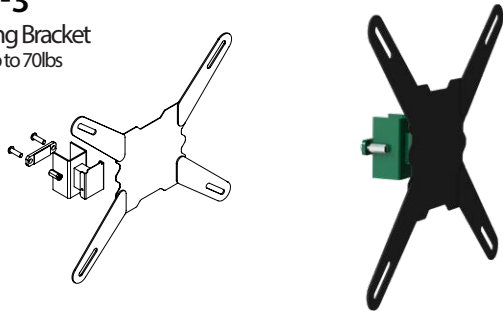

PN: DA-4
TV Angle Sign Bar

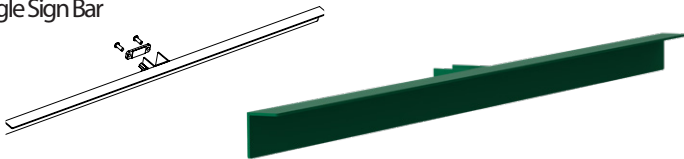

PN: TBS-1
T-Bar Shelf

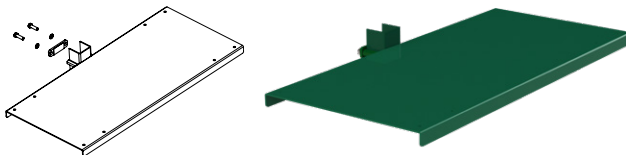

Note: Shown as complete system. All items are sold separately.

PN: DA-2HD
(for DS-1HD)

PN: DA-2
(for DS-1)



MAJORS AREA UPGRADE



TV RETENTION T-BAR

PN: RB-1

Designed to support merchandise stored beneath the platform. Ideal for large screen TV's. Quick release for removing boxed TV's.

Features:

- 1- 31" vertical bar
- 1- 10" base

Specifications:

- 31" high
- 12" wide
- 10" base
- Powder coated steel

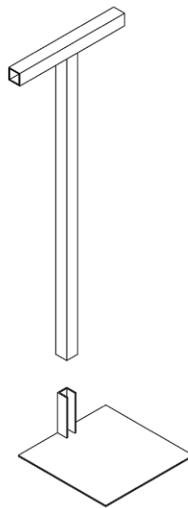

ADJUSTABLE RETENTION BAR

PN: RB-4

Adjusts to support various size TV's stored beneath the platform. Quick release for removing boxed TV's.

Features:

- 1- adjustable vertical bar assembly
- 1- 10" base

Specifications:

- Adjusts 31" to 49" high
- 12" wide
- 10" base
- Powder coated steel

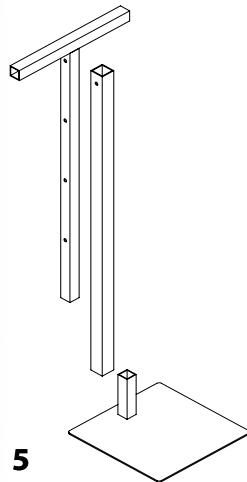

METAL TABLE TOPS

The ideal replacement to outlast melamine when displaying clothing, books, baked goods, or other merchandise. Choose the tabletop that best for your configuration including with or without stiffeners and narrow fit tops.

Without Stiffeners

Additional support is recommended for maximum load bearing capability

With Stiffeners

Enhanced dust, liquid, & debris flow-through with built-in load bearing supports. No additional support needed.

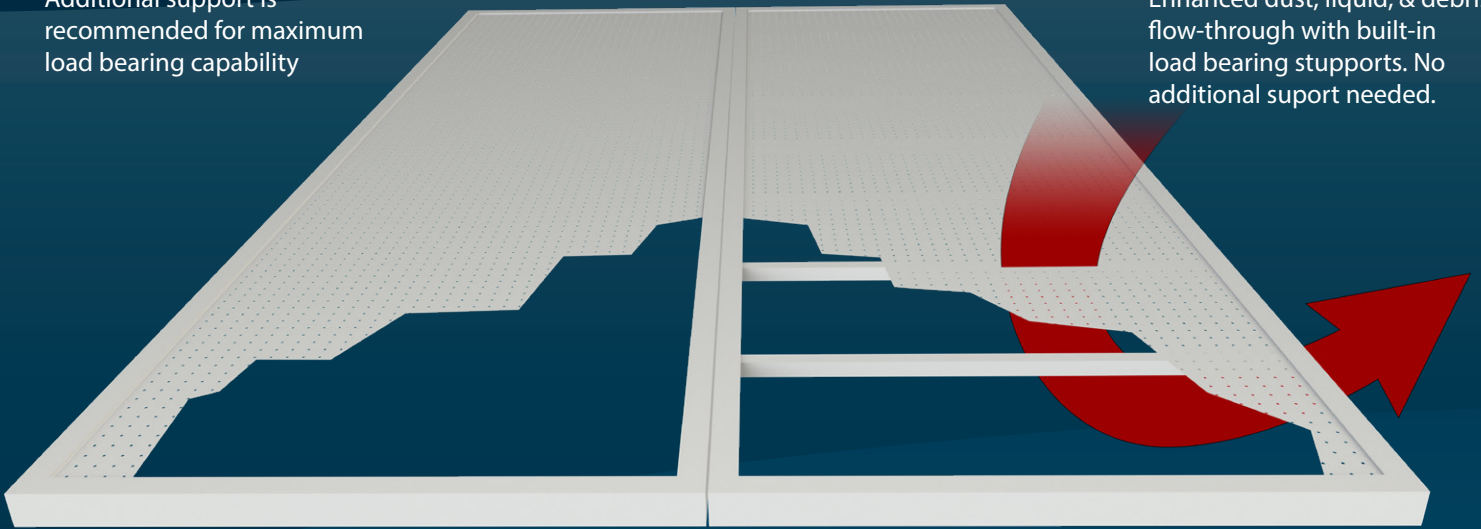

Depending on the display configuration in various areas around your store, you have the option to choose between narrow-fit and wide-fit tabletops.

Narrow Fit

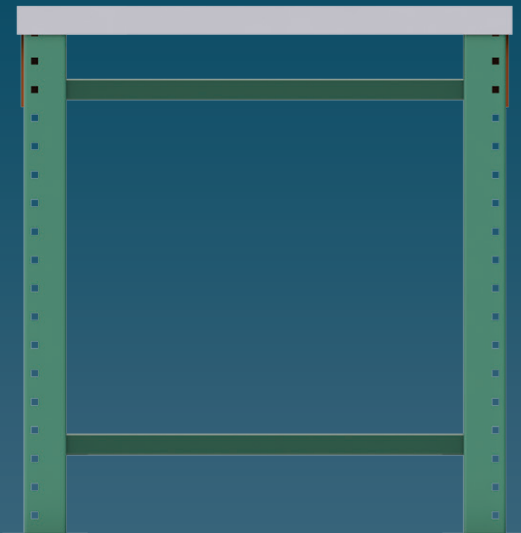

Wide Fit

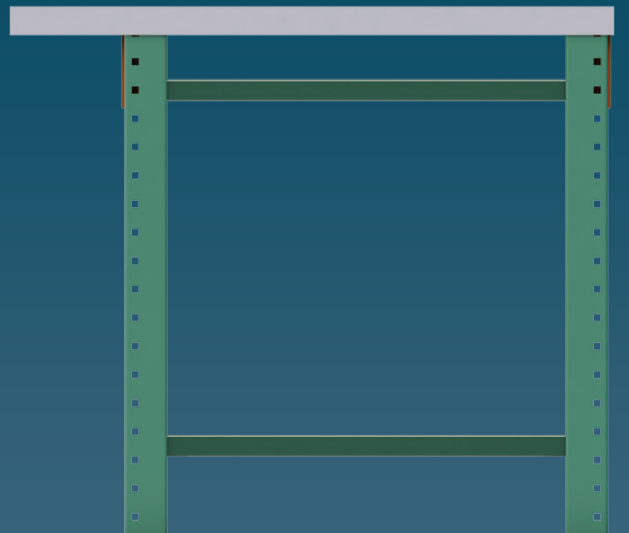

Wide Fit is recommended for tables using the 12" spacer bracket between the green uprights.

EXPERIENCE THE BENEFITS OF METAL TABLETOPS

Features:

All metal construction
Perforated steel surface
Available with and without stiffeners

Specifications:

Available for 9' long tables
2" high frame
Powder coat finish

Narrow Fit

PN: TT-1 9' Narrow Fit, With Stiffeners

PN: TT-6 9' Narrow Fit, No Stiffeners

Wide Fit

PN: TT-2 9' Wide Fit, With Stiffeners

PN: TT-5 9' Wide Fit, No Stiffeners

Call for more details about custom sizes and colors.



Note: Shown with 2 wide fit table tops installed using a spacer bracket.

TABLE TOP EDGE GUARDS

Protect your existing melamine table tops. Heavy gauge metal guards to ensure smooth sides, corners, and tops.

Features:

- All metal construction
- Quick and easy to install
- Powder coated finish

Specifications:

- 2" high frame
- Custom fit to table size
- Fine thread machine bolts

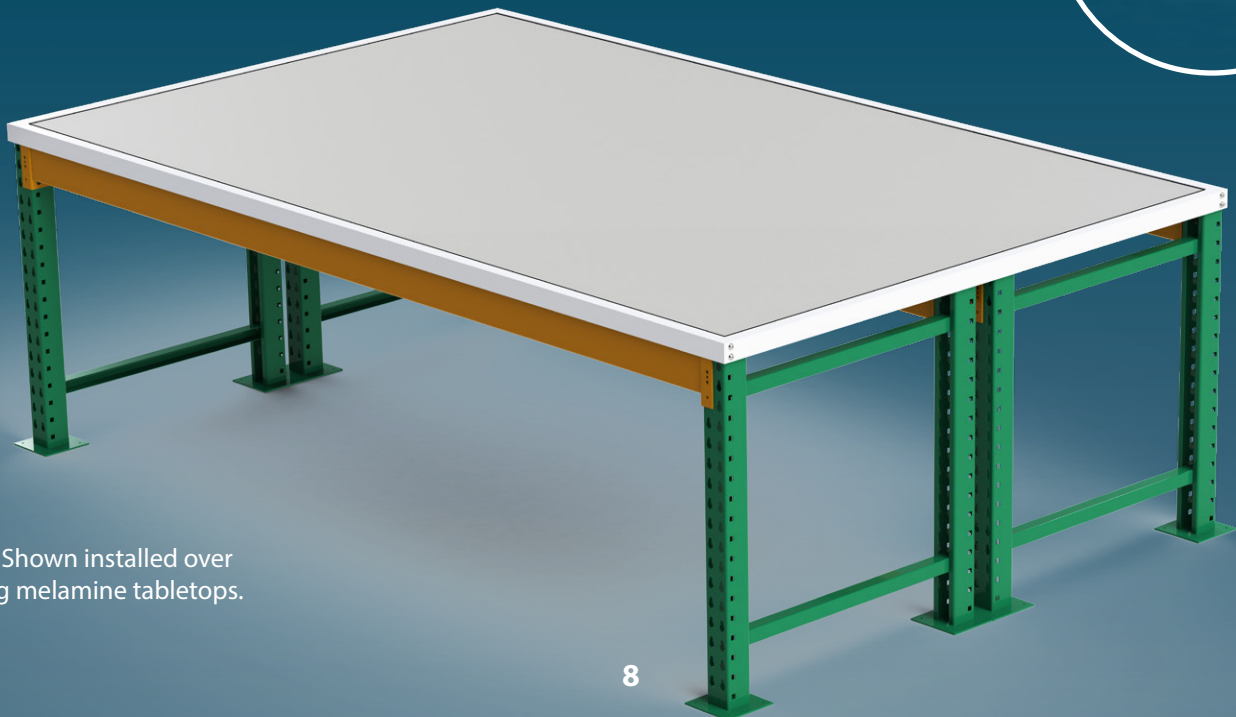
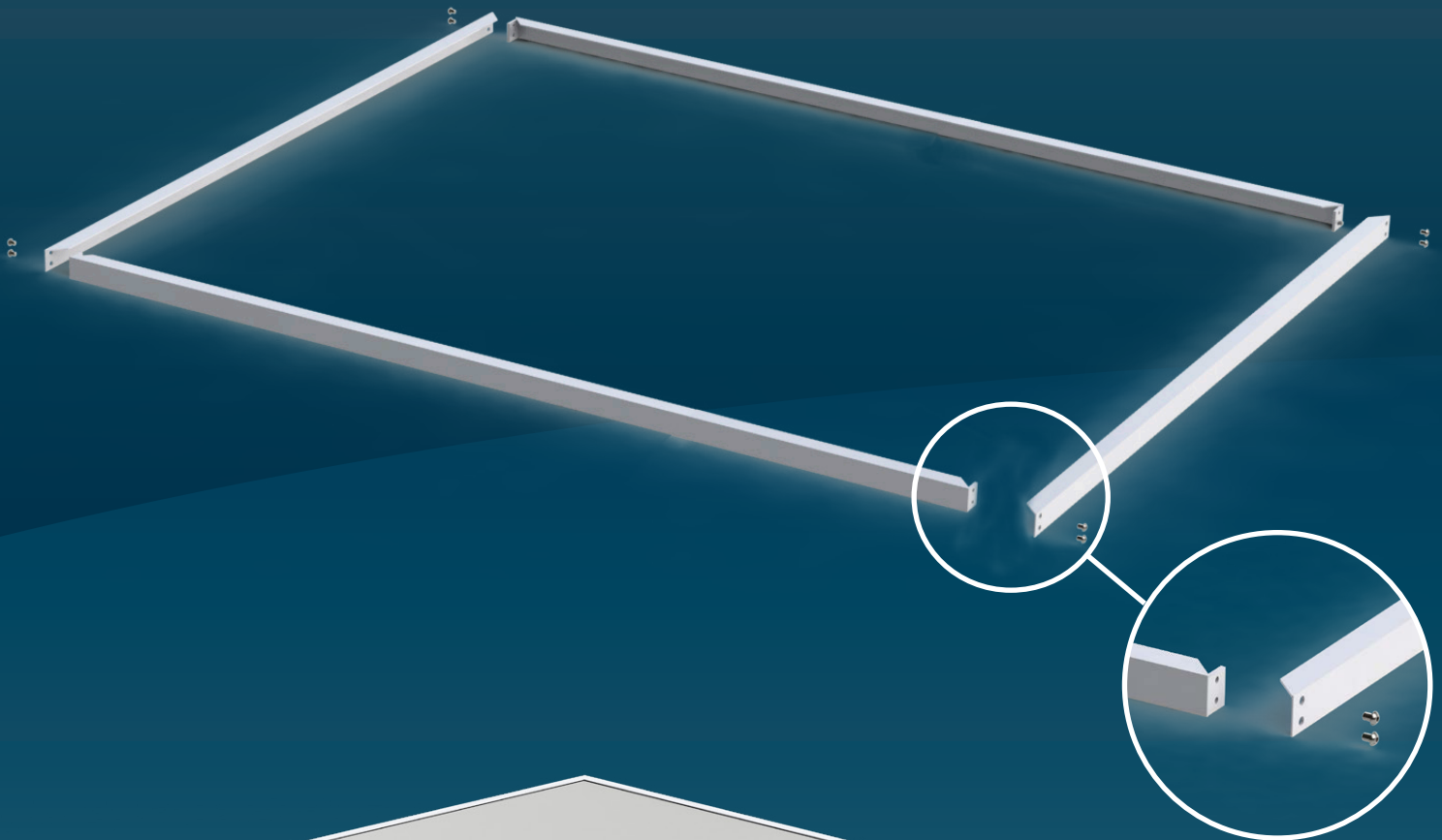

Note: Shown installed over existing melamine tabletops.

HIGH CAPACITY CLOTHING HANG BAR

The ultimate display for your hang stock is our new High-Capacity Clothing Hang Bar.

Weight restrictions apply.

Features:

1.50" round tube, 2" gussets, adjustable length, mini T-Bar sign pole

Specifications:

56.5" wide

Expandable to fit 6' to 9' beams

Powder coated finish

PN: HB-2

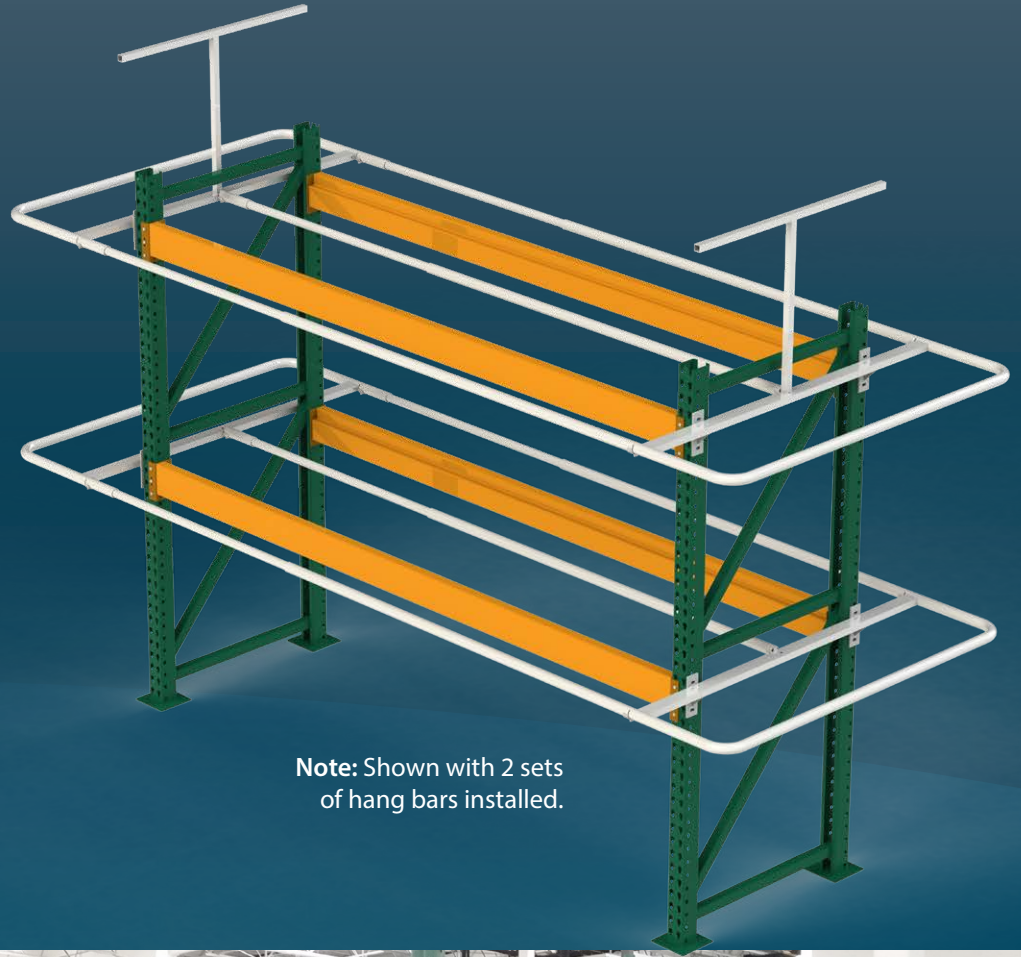

Note: Shown with 2 sets of hang bars installed.



HIGH CAPACITY CLOTHING HANG BAR EXTENSION

Easily converts 9' sections to 18' continuous hanging sections.

Features:

4 bolt design, 2" gussets

Specifications:

56.5" wide

3/8" mounting hardware included

Powder coated finish

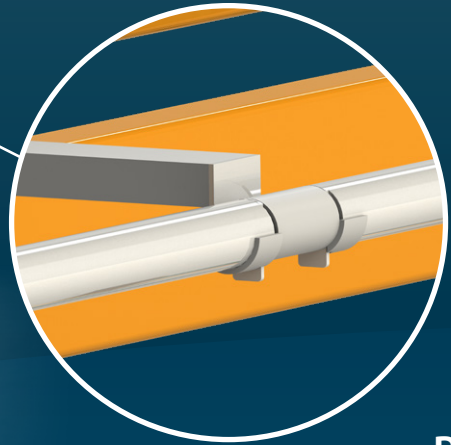
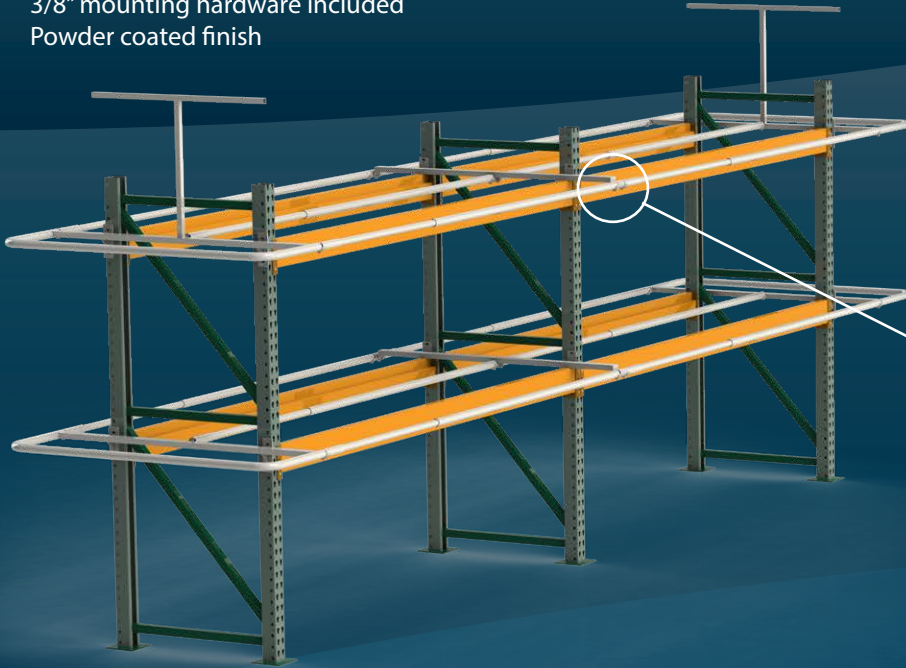
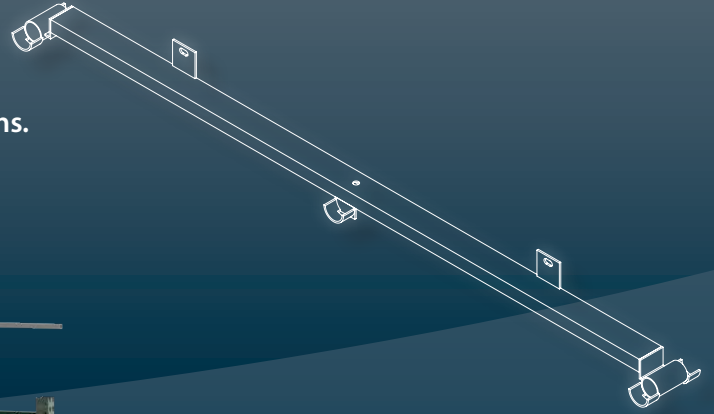

PN: HB-3

HIGH CAPACITY CLOTHING HANG BAR VERTICAL DISPLAY ARM

A set of two vertical extensions that work in combination with our High Capacity Hang Bar (HB-2).

PN: HB-6

Backstock Bar
(included with High Capacity Hang Bar)

Angle Sign Bar - DA-4
(Sold Separately)

High Capacity Hang Bar - HB-2
(Sold Separately)

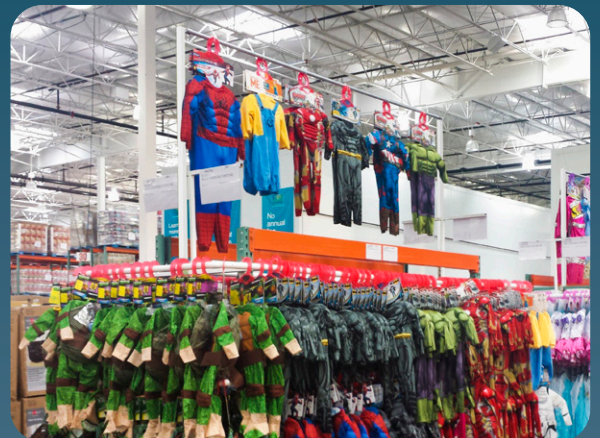
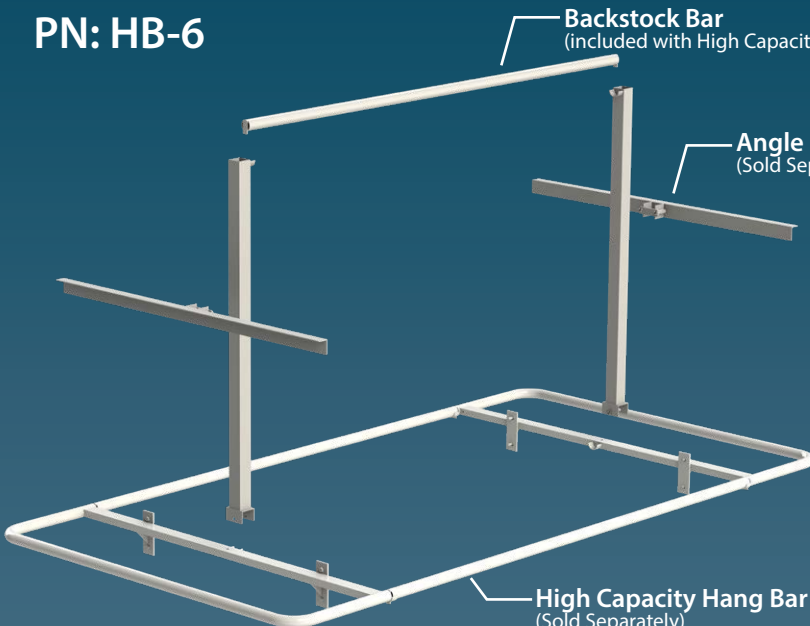
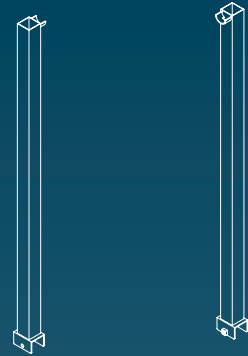



HIGH CAPACITY CLOTHING HANG BAR SUPPORT BRACKET

Designed for use on a standard 9' beam, this bracket supports High Capacity Clothing Hang Bars (HB-2) when displaying heavier garments.

PN: HB-4 for Ridg-U-Rak Steel

PN: HB-5 for Hannibal Steel

HIGH CAPACITY CLOTHING HANG BAR STORAGE FIXTURE

Designed to be fastened on a standard sized pallet. The PALette Hang Bar Storage Solution is capable of storing eight sets of High Capacity Clothing Hang Bars (HB-2) with accessories. It can be stored securely in your pallet racking and moved around on a pallet jack or forklift.

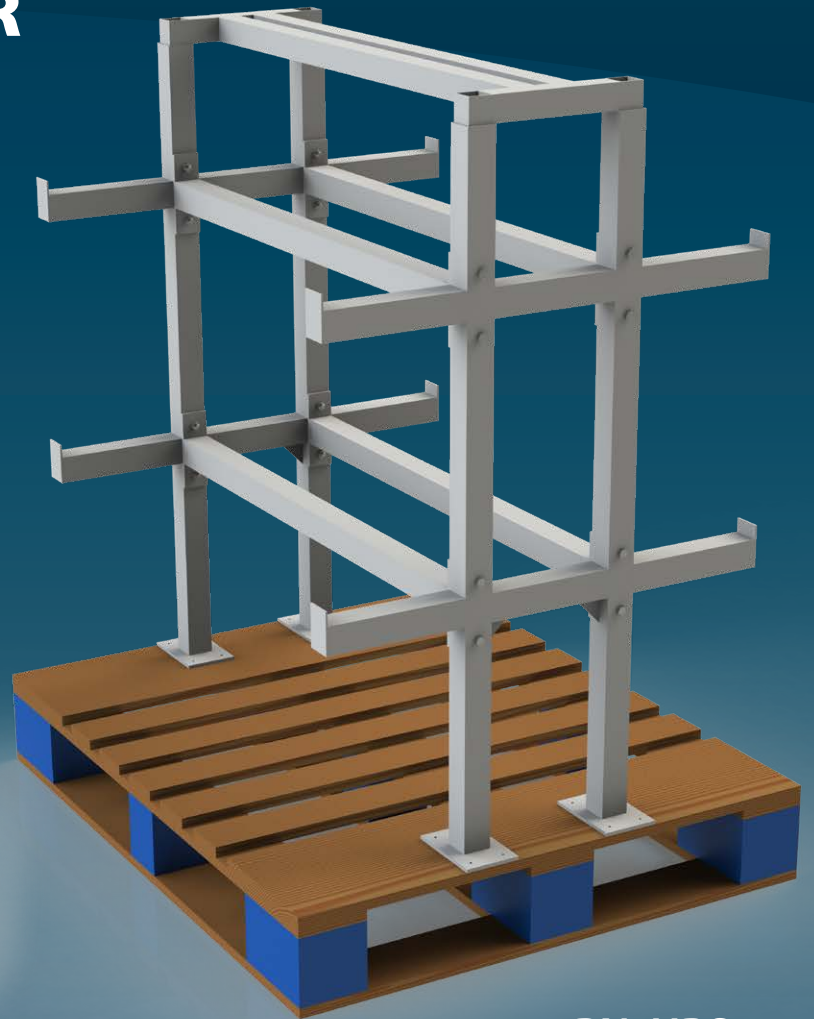
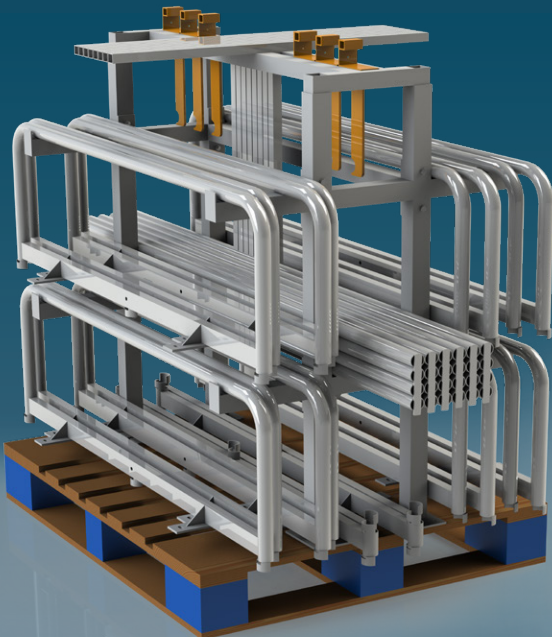

Note: Shown with 8 sets of hang bars and accessories, sold separately.

PN: HBS-1

TBar SYSTEM

Modular Merchandising Solutions

Wirefab/CSource's 42+ years of fixture design and engineering know how, has resulted in a line of effective warehouse merchandising fixtures with premium quality and value.

The true merit of a modular system lies in the durability, and adaptability of its combined components. This is achieved with the use of the SturdyLock technology, a solid yet simple tensioning system that can withstand the challenges of the ever changing warehouse floor. All CSource modular T-Bars have integrated SturdyLock so there is no hardware to contend with, making for quick assembly, easy storage, and endless options to meet any merchandising challenges.

STURDY LOCK!
MODULAR WITH

UNLOCKED POSITION

3/8" HEX WRENCH
THE ONLY TOOL REQUIRED FOR FULL ASSEMBLY

LOCKED POSITION



NO MORE FULLY WELDED T-BARS

DID YOU KNOW?
We can ship

20 T-BARS
ON ONE PALLET

3-PC MODULAR



and...

18 T-BARS
ON ONE PALLET

2-PC MODULAR

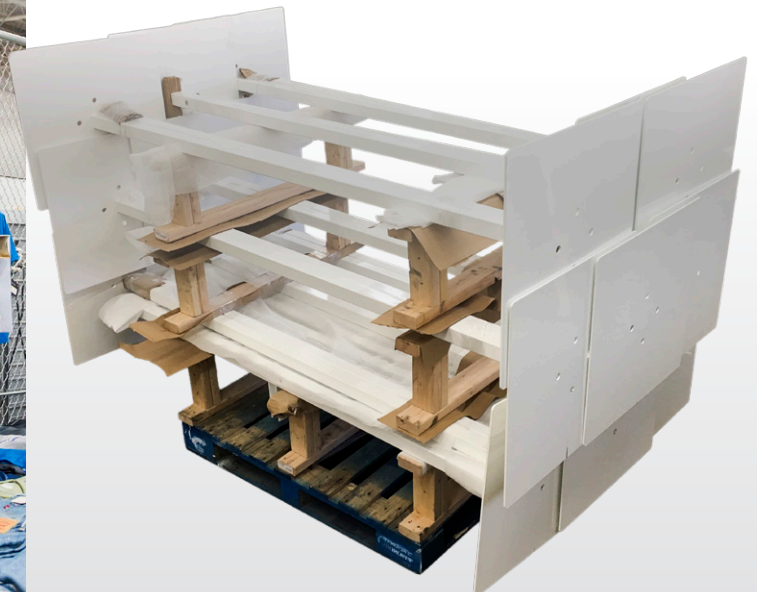

MODULAR T-BAR MERCHANDISING SYSTEM

Developed by Merchandising Managers -- engineered and built by Wirefab / CSource

LARGE 3-PIECE T-BAR

PN: TB-1

The standard T-Bar with the additional benefit of modularity. Allows for quick and easy take-down and set-up to reduce back injuries. Components efficiently store in the backroom. Best if combined with the 3pc Storage PALette.

Features:

- 1- large horizontal bar
- 1- large vertical bar
- 1- 12" or 24" base

Specifications:

2" sq tube, 84" high, 76" wide, 24" base,
Powder coated steel (custom sizes available)



LARGE 2-PIECE T-BAR

PN: TB-3

The standard T-Bar with the additional benefit of modularity. Allows for quick and easy take-down and set-up to reduce back injuries. Components efficiently store in the backroom. Best if combined with the 2pc Storage PALette.

Features:

- 1- large horizontal bar
- 1- large vertical bar welded to 12" or 24" base

Specifications:

2" sq tube, 84" high, 76" wide, 24" base,
Powder coated steel (custom sizes available)

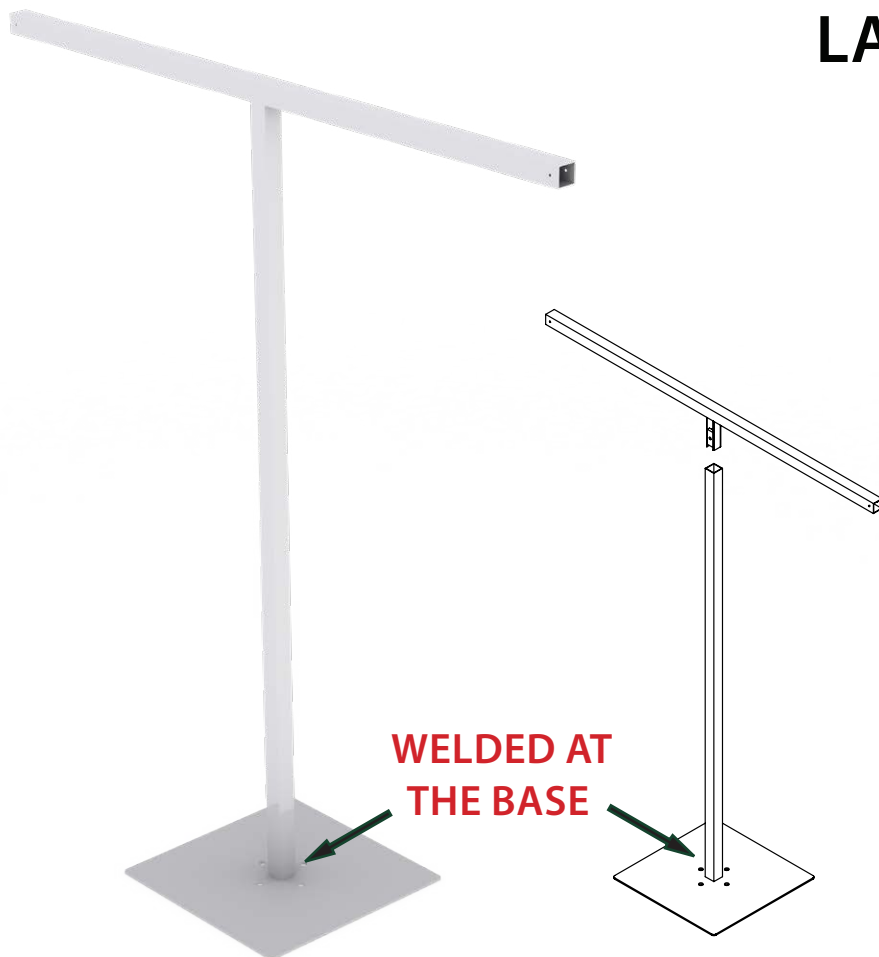

SMALL 3-PIECE T-BAR

PN: TB-2

Designed for use with table or pallet stacks. The Small T-Bar set seamlessly interfaces with the Large T-Bar components and all T-Bar shelving systems.

Features:

- 1- small horizontal bar
- 1- small vertical bar
- 1- 12" or 24" base

Standard Specs:

2" sq tube, 42" high, 60" wide, 12" or 24" base,
Powder coated steel (custom sizes available)



SMALL 2-PIECE T-BAR

PN: TB-4

Designed for use with table or pallet stacks. The 2pc Small T-Bar set interfaces with other modular T-Bar components and T-Bar shelving systems.

Features:

- 1- small horizontal bar
- 1- small vertical bar welded to 12" or 24" base

Standard Specs:

2" sq tube, 42" high, 60" wide, 12" or 24" base,
Powder coated steel (custom sizes available)



SMALL 1"-STYLE T-BAR

PN: TB-7

Designed for use with table or pallet stacks in centers, our new 1" T-Bar is a light-weight, cost-saving alternative to the 2" sq. tube T-Bar.

Features:

1- small horizontal bar welded to the vertical
1- 6" or 12" base

Standard Specs:

1" sq tube, 42" high, 48" wide, 6" or 12" base,
Powder coated steel (custom sizes available)



PRODUCE T-BAR

PN: TB-10

Smaller than our Large T-Bar, for use in the produce area. These T-Bar components interface with other modular T-Bar components and T-Bar shelving systems.

Also available in: 2-piece (PN:TB-11)

Features:

1- large horizontal bar
1- large vertical bar
1- 12" or 24" base

Specifications:

2" sq tube, 72" high, 60" wide, 24" base,
Powder coated steel (custom sizes available)



PALETTE (3-PC) T-BAR STORAGE SOLUTION

PN: TBP-1

Designed with the same footprint of a standard sized pallet. The 3-pc PALette T-Bar Storage Solution is capable of storing up to twelve modular 3-pc T-Bars along with six T-Bar shelves. It can be stored securely in your pallet racking, and moved around on a pallet jack or forklift.

Features:

- 1- pallet base
- 1- tube storage module
- 1- base storage module
- 1- shelf storage rack

Specifications:

40" x 48", 54" tall, Powder coated steel

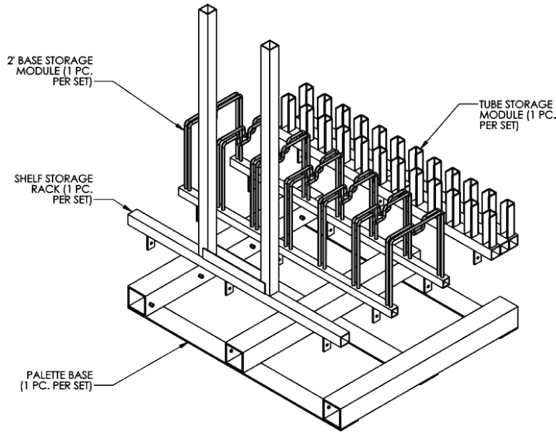

SAFELY MOVE AND STORE T-BARS AROUND YOUR WAREHOUSE



Note: Shown loaded with (12) Large, 3pc T-Bars and Accessories. Sold Separately

PALETTE (2-PC) T-BAR STORAGE SOLUTION

PN: TBP-2

Designed to be fastened on a standard sized pallet. The 2-pc PALette T-Bar Storage Solution is capable of storing modular 2-pc T-Bars. Easily and securely store T-Bars in your pallet racking, or move them around with a pallet jack or forklift.

Features:

1- fully welded palette base

Specifications:

50" x 48", 7.5" tall, Powder coated steel



Note: Shown loaded with (6) Large, 2pc T-Bars. Sold Separately

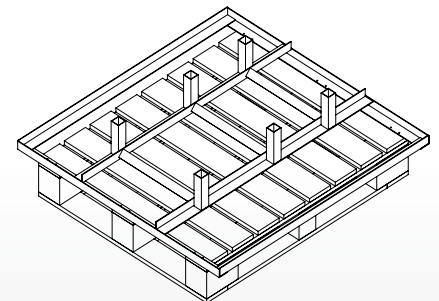

**24" BASE VERSION
HOLDS (6) 2PC TBARS**

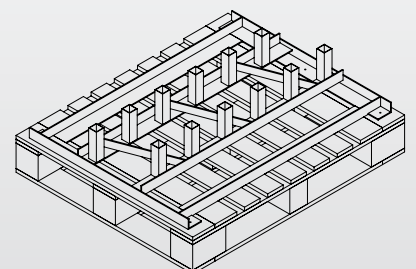

**12" BASE VERSION
HOLDS (12) 2PC TBARS**

ADJUSTABLE T-BAR

PN: ATB-1

This versatile T-Bar adjusts in height from 56" to 84" in three inch increments, opening the door to a whole new range of merchandising possibilities, like challenging seasonal displays. These T-Bar componets interface with other modular T-Bar componets and T-Bar shelving systems.

Features:

- 1-adj. vertical bar assembly
- 1-horizontal bar
- 1-24" base
- Standard 3/8" hardware included

Specifications:

- Adjusts 56" to 84" high, 60" wide, 24" base,
- Powder coated steel

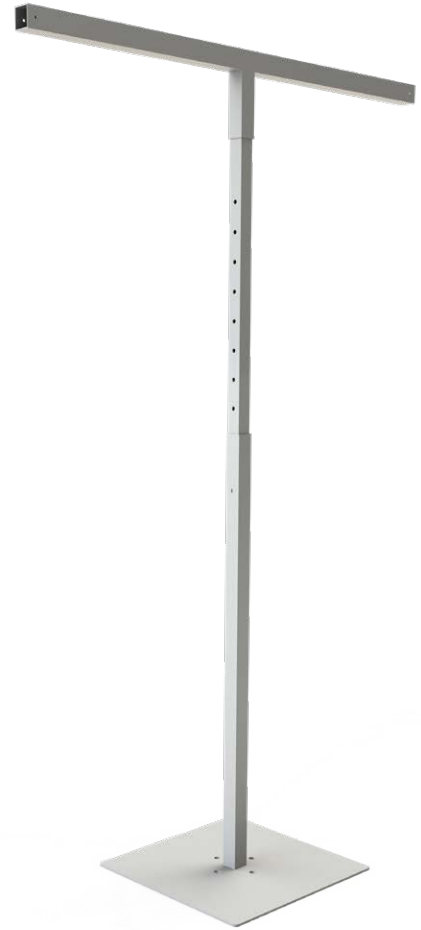
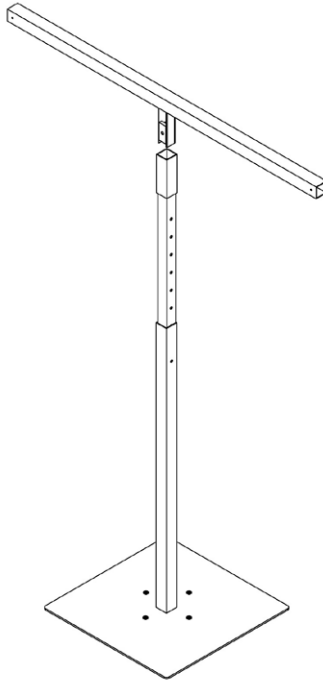

ADJUSTABLE SIGN LINE POLE

PN: ATB-2

A great solution for sign posting fence line pick-stock. The adjustable cable pole is capable of running sign line at varying heights between 78" and 108".

Features:

- 1- adjustable sign-line assembly
- 1- 24" base
- Standard 3/8" hardware included

Specifications:

- Adjusts 78" to 108" high, 24" base,
- Powder coated steel

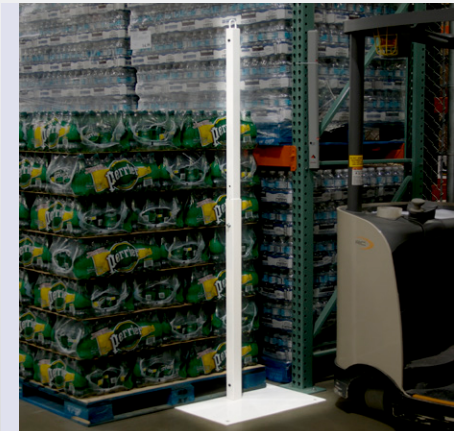
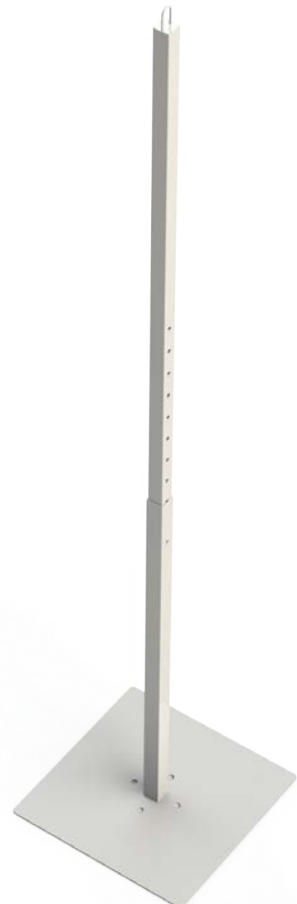
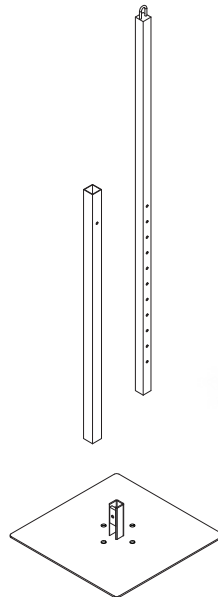

ADJUSTABLE MOUNTING BAR

PN: ATB-5

Designed for quads in the majors area. Add TV Mounting Bracket, Angle Sign Bar, and T-Bar Shelf for displaying TV's and sound bars (accessories sold separately).

Features:

- 1- adjustable vertical bar assembly
- 1- 24" base
- Standard 3/8" hardware included

Specifications:

Adjusts 55" to 82" high, 2" sq tube, 24" base, Powder coated steel



TV Mounting Bracket (DA-3)

OPTIONAL

TV Mounting Bracket HD (DA-3HD)

Angle Sign Bar (DA-4)

T-Bar Shelf (TBS-1)

Note: accessories shown sold separately

Adjustable Mounting Bar (ATB-5)

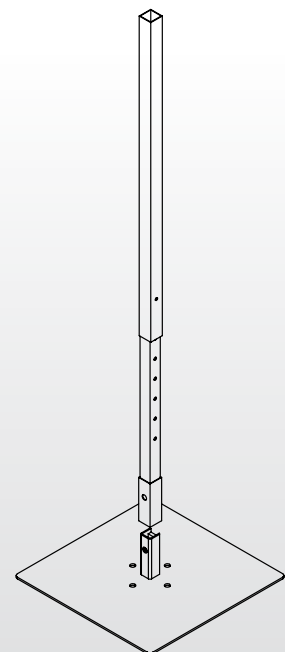

LARGE FREESTANDING ADJUSTABLE SHELF

PN: ATB-4

Originally designed with two shelves, the new large adjustable freestanding shelf will accommodate larger TV's and a variety of merchandise such as bicycles and seasonal items.

Features:

- 1- adjustable vertical bar assembly
 - 1- large shelf with zip-tie mounting holes
 - 1- 24" base
- Standard 3/8" hardware included

Specifications:

Adjusts 44" to 62" high, 48" wide x 32" deep shelf, 24" base, Powder coated steel

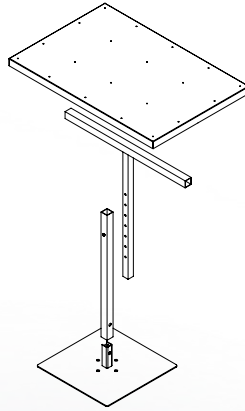

T-BAR TOP SHELF

PN: TBS-2

Developed to 'float' display models. Designed for mounting on a standard 2" square tube.

Also available in larger size (PN:TBS-3)

Features:

- Zip-tie mounting holes on shelf
- 3/8" mounting hardware included

Specifications:

TBS-2 - 48" wide x 32" deep

TBS-3 - 60" wide x 36" deep

Powder coated steel



Note: fits on standard T-Bar sold separately

FREESTANDING ADJUSTABLE SHELF

PN: ATB-3

This adjustable freestanding shelf has been used in many creative ways to merchandise a wide variety of items. One example is to place the shelf within a 4-square to display large electronic items such as stereos, phone sets, and video game consoles.

Features:

- 1- adjustable vertical bar assembly
 - 1- large shelf with zip-tie mounting holes
 - 1- 24" base
- Standard 3/8" hardware included

Specifications:

Adjusts 44" to 62" high, 24" base, 48" wide x 14.5" deep, Powder coated steel



T-BAR SHELF

PN: TBS-1

Developed to 'float' display models. Designed for mounting on a standard 2" square tube.

Features:

- Zip-tie mounting holes on shelf
- 3/8" mounting hardware included

Specifications:

32" wide, 14.5" deep, Powder coated steel

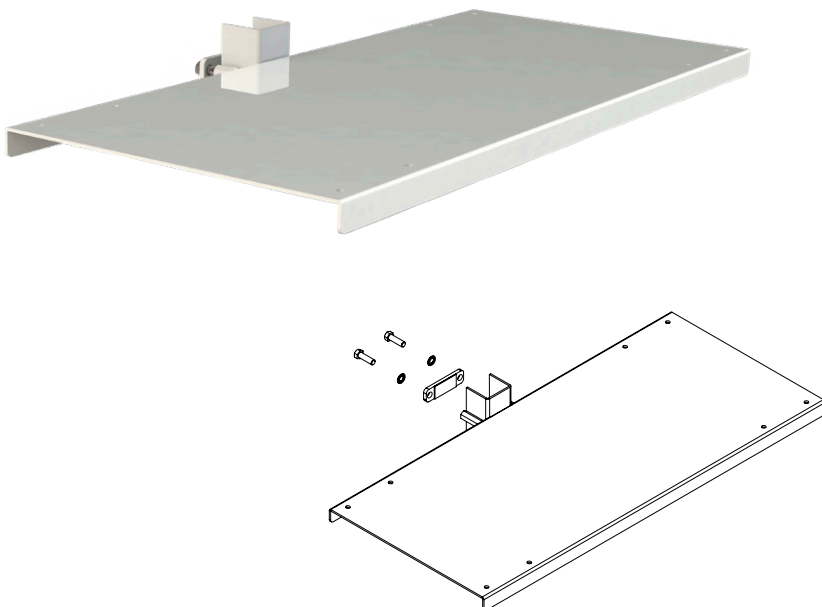

PLANT T-BAR

PN: TB-6

Convenient for plant displays. Modularity allows for quick and easy take-down and setup. Components efficiently store in the backroom.

Features:

- 1- horizontal bar with fixed vertical bar
- 1- 10" x 10" base

Specifications:

- 36" high, 24" wide, 10" x 10" base,
- Powder coated steel

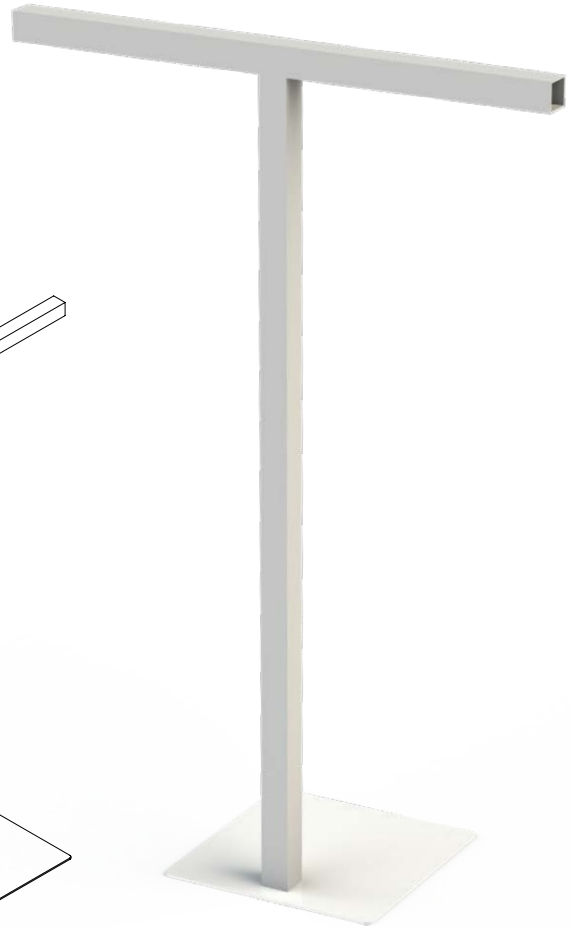
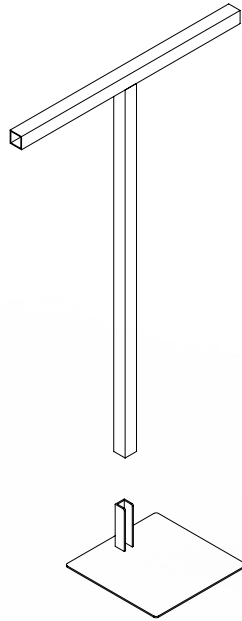

PLANT SIGN BAR

PN: TB-8

Designed for the garden center to be used as a single plant sign holder. Lightweight design for easy and convenient use and storage.

Features:

- 1- vertical bar with 5"x7" fixed sign plate
- 1- 10" x 10" base

Specifications:

- 36" high, 10" x 10" base, Powder coated steel

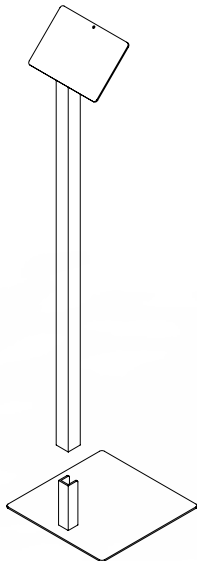

CLOTHING DISPLAY ARM

PN: TBA-1

Designed to attach to any standard 2" T-Bar.
Conveniently displays hanging merchandise.

Also available in: 1" clamp design. (PN:TBA-2)

Features:

Easy installation, no sharp edges, powder coat finish

Specifications:

36" high, 5" wide hanger,
5/16-18 bolt head,
Powder coated steel

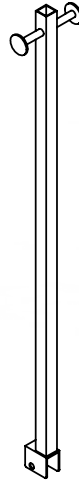

T-BAR EXTENDED SIGN BAR

PN: TB-9

Designed to extend the sign bar space. Attaches to 2" square T-Bar.

Features:

1- horizontal sign bar extension

Specifications:

32" wide x 32" deep
Powder coated steel

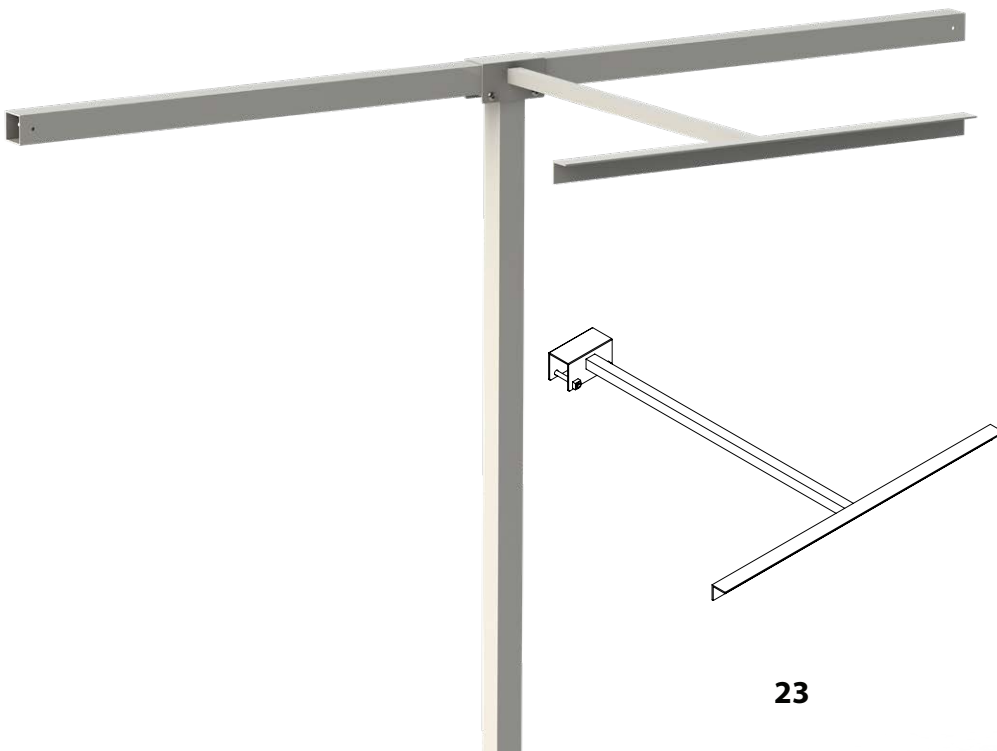

HEIGHT ADJUSTABLE FOLDING TABLE

PN: FT-1

Designed to provide a balanced combination of functionality, ergonomics and durability, the folding table is your best defense in the relentless battle of keeping folded goods tidy and soft-lines moving.

Features:

All metal construction, fold-out top surface, adjustable height, 3.5" bumpers

Specifications:

18" wide, 38.5" length, 35"-42" high, fold-out top surface adds 18", 4" swivel/non-marking casters, Black powder coat finish



NOTE: Folding board sold separately



FLIP-FOLD FOLDING BOARD

PN: FB-1

FlipFOLD can fold any size shirt (small-XXXL) to a uniform size 9"x12" in five seconds, for a consistent uniform fold every time.

Features:

Fits in folding table holder, no sharp edges



TABLE PRODUCT SUPPORT

PN: PS-1

Designed to support tall stacks of merchandise displayed on tables. Ideal for organizing blister pack and folded garments. Also available in multiple sizes.

Features:

clear, unbreakable PETG material, radius corners with no sharp edges, high friction feet mounted on the base to provide excellent adhesion to the table.

Specifications:

PS-1 - 12" high, 12" wide, 7.5" deep

PS-4 - 12" high, 46" wide, 7.5" deep (Extra-wide)

PS-5 - 12" high, 12" wide, 7.5" deep (Corner)

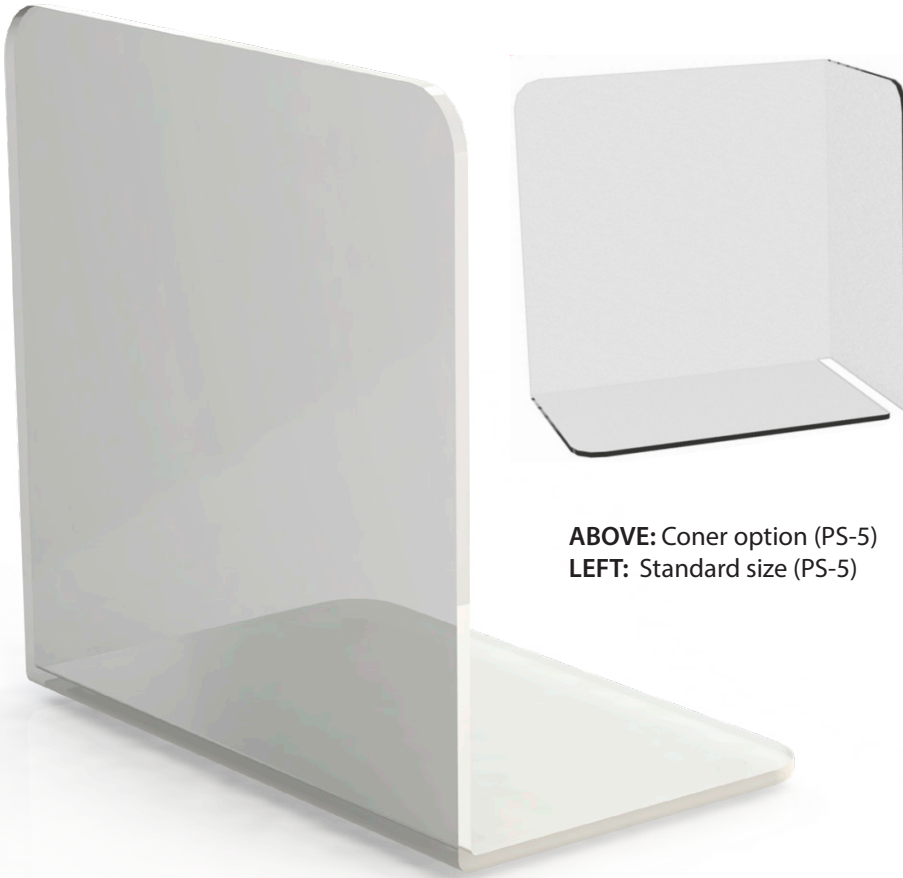

ABOVE: Corner option (PS-5)
LEFT: Standard size (PS-1)

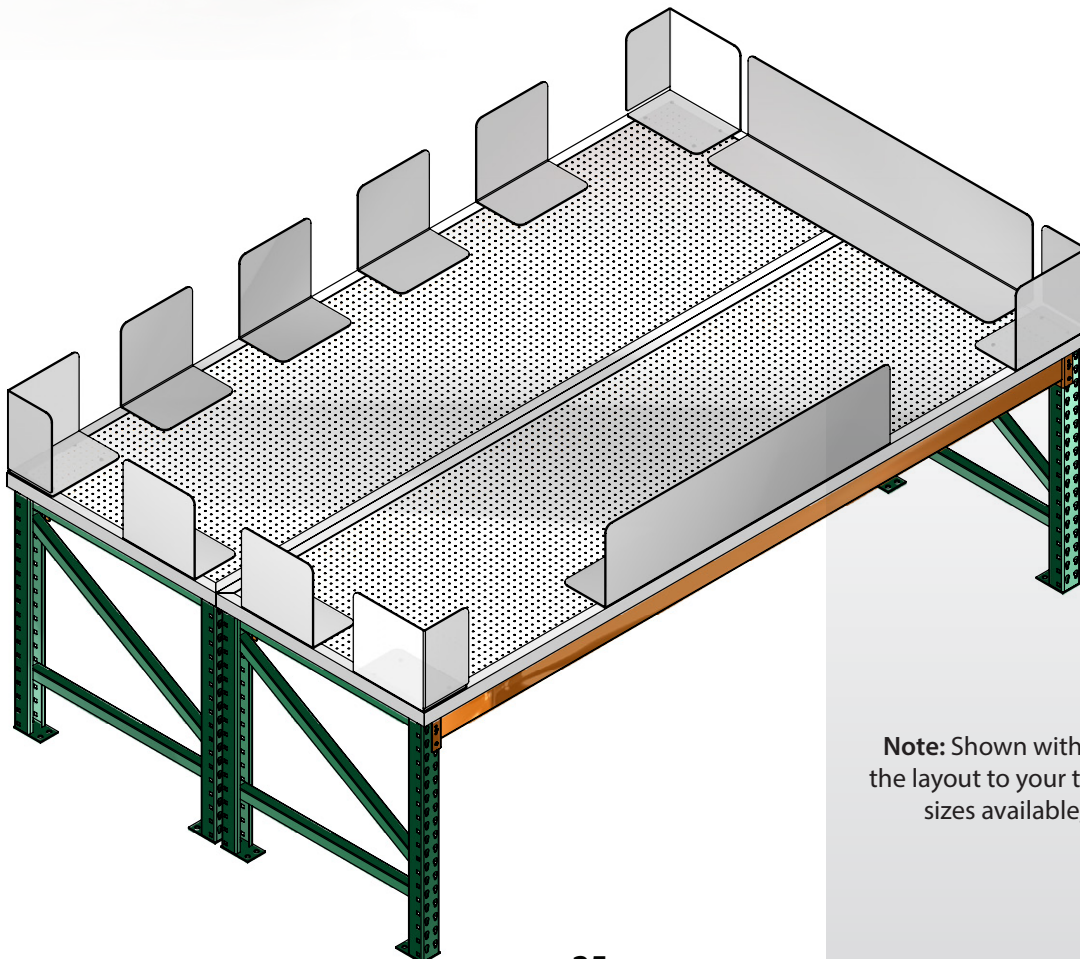

Note: Shown with various sizes to fit the layout to your table needs. Custom sizes available, call for details

PRODUCT DISPLAY TABLE & ADD ON SHELF

PN: PD-1

The newly redesigned Product Display Table features reinforced shelves for supporting heavyweight merchandise. The knockdown design provides cost efficient shipping and convenient backroom storage.

Features:

Heavy duty frame, reinforced shelves, fits 40"x 48" pallet

Specifications:

48" high, 39.75" wide, 47.75" long, equal shelf spacing: 22", Black powder coated steel

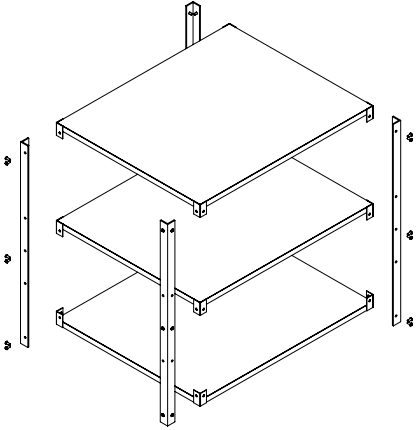

PN: PD-2

The optional Add-On Shelf offers versatility to the Product Display Table and allows for a wide variety of merchandise to be displayed with less open display space.

Features:

Heavy duty frame, reinforced shelf

Specifications:

Equal shelf spacing becomes: 14"
Black powder coated steel

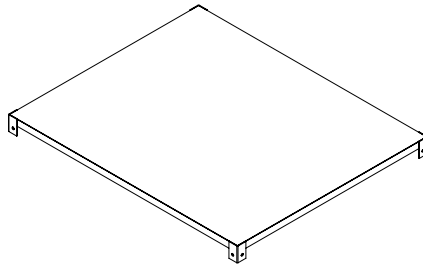

Note: Configuration in back shows the Product Display Table with Add On Shelf included, items sold separately.

MOBILE MARKETING STATION

PN: ECT-1

Designed for Ecommerce ordering or as a mobile marketing station. Provide customers access to the expanded selection, or for other marketing signups and advertising.

Features:

- 3" Twin wheel locking casters
- 2 - Clear acrylic brochure holders
- 2 - Removable logo panels for inside storage

Specifications:

36" length, 42" width, 42" high, Powder coat steel frame, MDF tabletop & side panels



TV Mounting Bracket (DA-3)
32"-55" TV's up to 70lbs

OPTIONAL

TV Mounting Bracket (DA3-HD)
50"-80" TV's up to 150lbs

Note: accessories shown
sold seperately

TV Mounting Pole/Base (TB-5)
Sold Seperately



CARDBOARD BOX BIN

PN: BB-1

Convenient storage for empty cardboard boxes. Easy to maneuver with large 5" swivel casters.

Features:

1" square tube, 5" polyloc grey swivel casters, knock-down design for storage

Specifications:

41" deep x 73" wide x 43" high
White powder coated steel

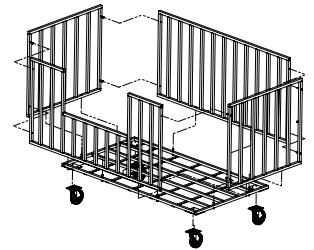

SLANTED PILLOW BIN

PN: PB-2

Designed to manage and merchandise various soft-line items. CSource Pillow Bins are easy to assemble and disassemble for convenient storage when not in use.

Features:

1" square tube, knock-down design for storage

Specifications:

48" long x 40" wide x 48" high
White powder coated steel

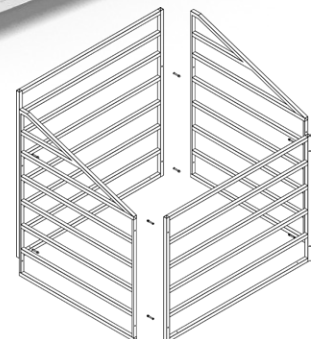

CHAIR STOP

PN: CS-1

Designed to secure office chairs to display platforms. The Chair Stops are easy to install using wood screws.

Sold in sets of 2.

Specifications:

3.5" diameter, 5" high, 1.75" deep, Powder coat satin black finish



TENT DISPLAY T-BAR

PN: TD-1

Designed to display fully assembled small tents and light weight inflatable products. The vertical pole is 108" tall. The product support arm is 48" wide and adjusts in length from 7' to 9'. The 24" wide base plate must be securely bolted to the floor.

Features:

- 1- 24" base
- 1- 108" vertical pole
- 1- Products support arm assembly

Specifications:

Product support arm adjusts 7' - 9'; Powder coated steel



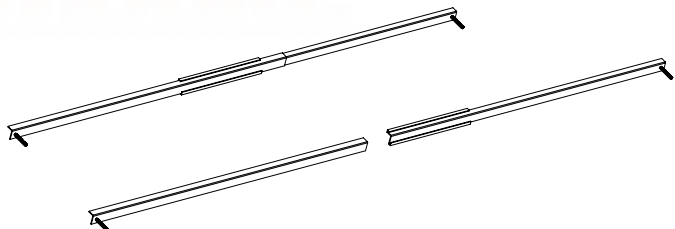

ADJUSTABLE ANGLE SIGN BAR

PN: AAH-1

Designed to expand and mount to all steel end caps. Two bolts attach the sign bar easily to the steel upright. Very economical to ship.

Specifications:
1/8" x 1" x 1 1/2" formed angle, adjustst 53" to 88", green powder coated finish

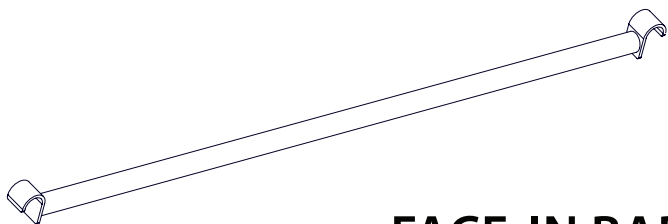

FACE-IN BARS

PN: RW-2

Face-In Bars work in unison with Face-Out Bars, allowing hang stock to be merchandised in an easy access, face-in position. This is ideal for clothing and sportswear such as jackets, wetsuits and life preservers.

Features:
1.25" round tube, Face-Out Bar compatibility

Specifications:
47.5" wide, black powder coated steel

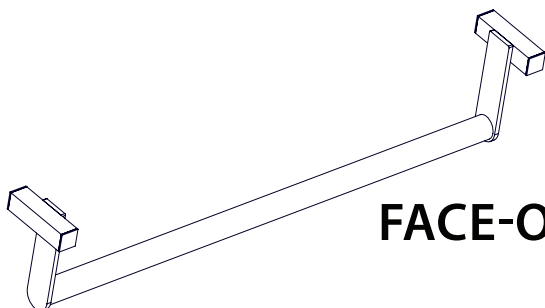

FACE-OUT BARS

PN: RW-3

Solve the challenge of merchandising standard and seasonal hang-stock. Individual RackWorks Face-Out Bars easily arrange to support and display all types of hanging items in an outwardly facing position.

Features:
1.25" round tube, easy-set span design, Face-In Bar compatibility

Specifications:
30.5" wide, 6" drop, black powder coated steel



RackWorks' smart and simple merchandising system makes it easy to organize and display various hard-line hang stock. Modular Face-In and Face-Out Bars work together to provide a combination of merchandising options for difficult-to-display hang items such as seat covers, floor mats, wetsuits, life preservers, and bicycles.

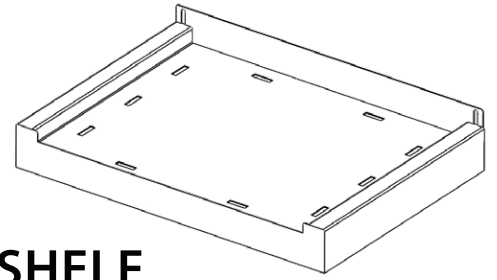

END-CAP SHELF

PN: RW-1

A refined solution to end-cap shelving, this attractive, low-profile shelf enhances the presentation of display items. (100lbs Maximum load capacity)

Features:

Easy mounting, secure strap slots, 3/8" mounting hardware included

Specifications:

34" wide, 24" deep, 3" high, powder coated finish

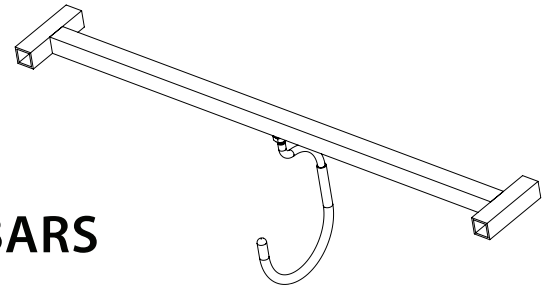

BIKE BARS

PN: RW-4

Streamline bicycle merchandising with easy-set adjustable Bike Bars. The custom wide-mouth hook makes mounting and removal easier by accommodating nearly all wheel and tire sizes.

Features:

Easy-set design, wide mouth hook, protective rubber sleeve

Specifications:

Easy-set, wide mouth hook, protective rubber sleeve

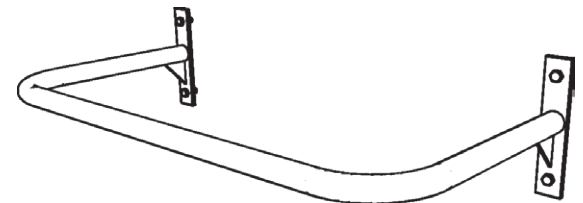

CLOTHING HANG BAR

PN: HB-1

The best way to expand your hang stock capacity is with our Clothing Hang Bar. (100lbs Hang weight capacity)

Features:

1.25" round tube

Specifications:

34" wide, 16" deep, powder coated finish, 3/8" mounting hardware included



CALL TODAY 888 861 9303 x104
csource.wirefabco.com



Wirefab has specialized in the design and manufacturing of custom products and displays for the retail industry for over 43 years. What sets us apart from other suppliers is the superior quality of our products, which ensures the highest return on your investment. We can fabricate from your design specifications or our experienced design and engineering staff can offer you creative ideas and practical solutions to meet your specific needs. From in-house prototyping to offshore production, Wirefab is able to offer competitive pricing with industry leading quality. From design to delivery, Wirefab is your best investment.

CUSTOM FIXTURES MADE TO ORDER!

YOU DESIGN IT, WE'LL MAKE IT!

The most creative and effective merchandising concepts often come from the associates that work the floor day in and day out.

Send us your merchandising ideas along with **DIMENSIONS** and **DESCRIPTIONS** to *CSource* by *Wirefab* and we will make it become a reality - quick and easy!

CSOURCE CUSTOM DESIGN SHEET

FAX TO 360 424 1976

Name _____ Title _____ Whs. No _____ Date _____
Phone _____ Fax _____ Email _____

PLEASE PROVIDE A ROUGH SKETCH WITH DIMENSIONS AND MATERIALS ALONG WITH A BRIEF DESCRIPTION BELOW.

Grid area for sketch and description. Includes a 'NOTES:' section at the bottom left of the grid.

Wirefab Company: 1012 W. Division Street, Mount Vernon, WA 98273 tel: 888.861.9303 fax: 360.424.1976 www.wirefabco.com



1012 W. Division Street
Mount Vernon, WA 98273

csource.wirefabco.com

Call or email for an order form/pricelist, or download from our website.
Questions? or need assistance with ordering? CALL US (360) 424-1129 - ext 104.